

TIME MACHINES

Diving deeper into timing machinery

TIME MACHINES

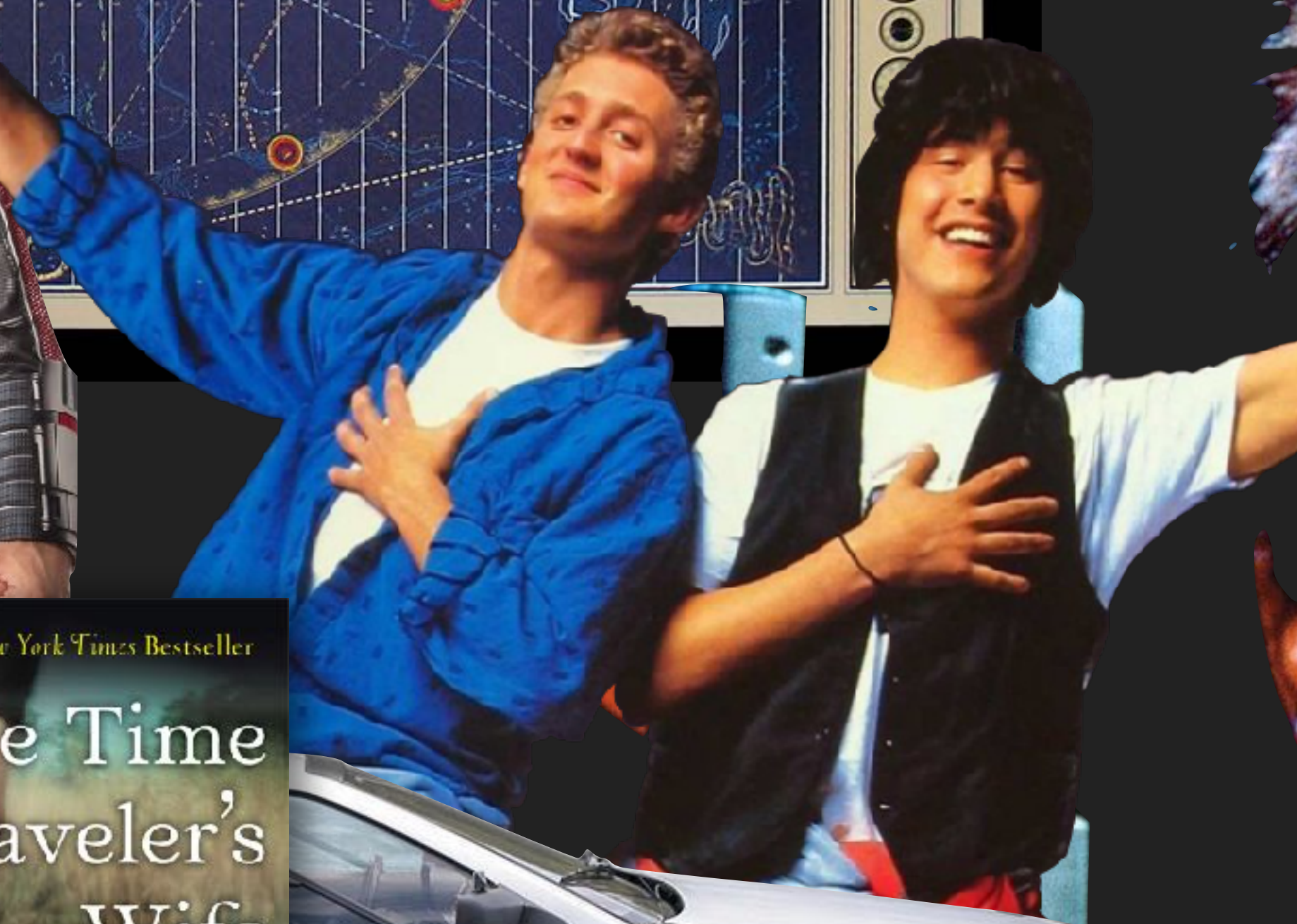

The Sensational New York Times Bestseller

The Time Traveler's Wife

"A scaring celebration of the victory of love over time."
—Chicago Tribune

POLICE PUBLIC CALL BOX



HOT TUB TIME MACHINE

TIM



**HOT TUB
TIME MACHINE**

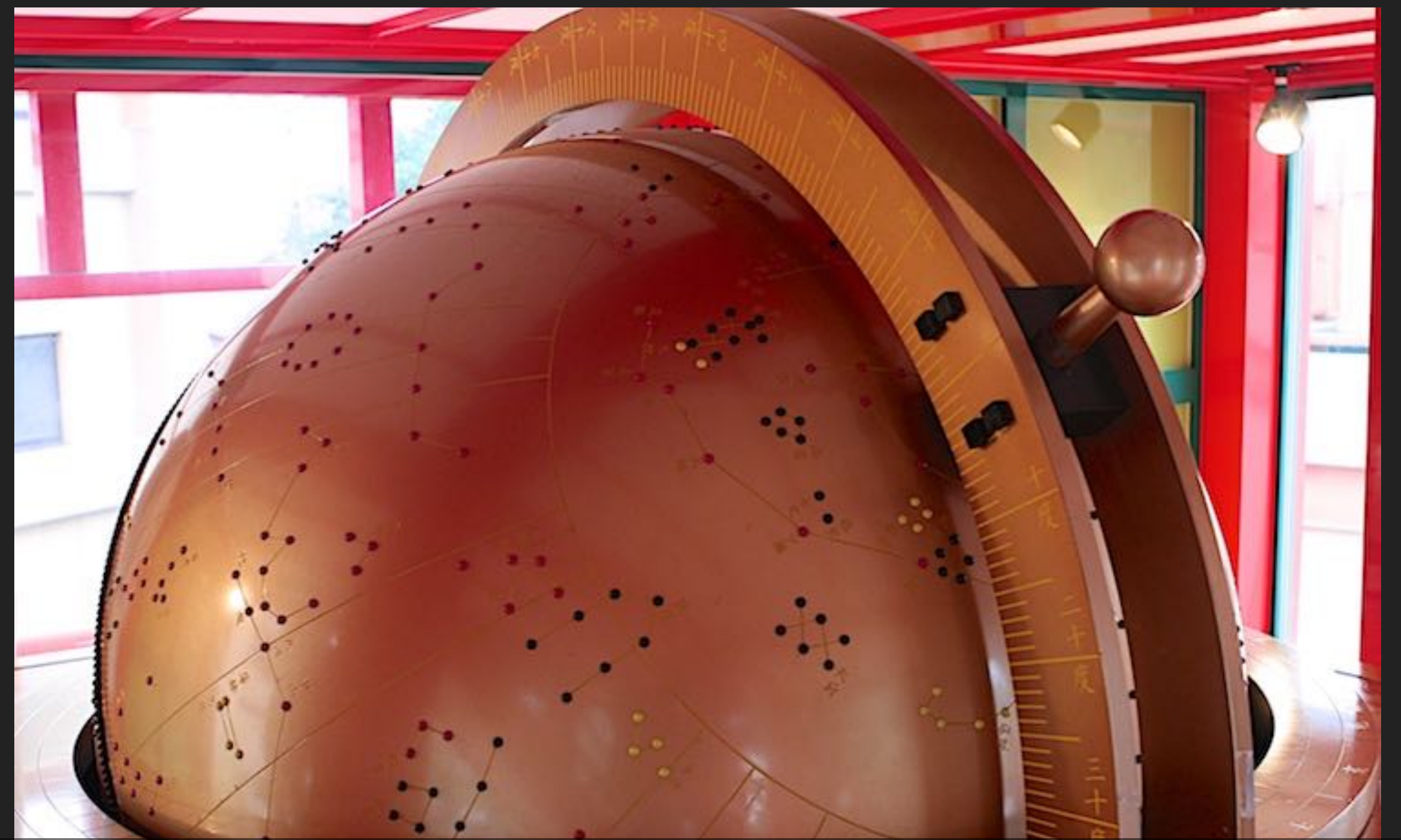
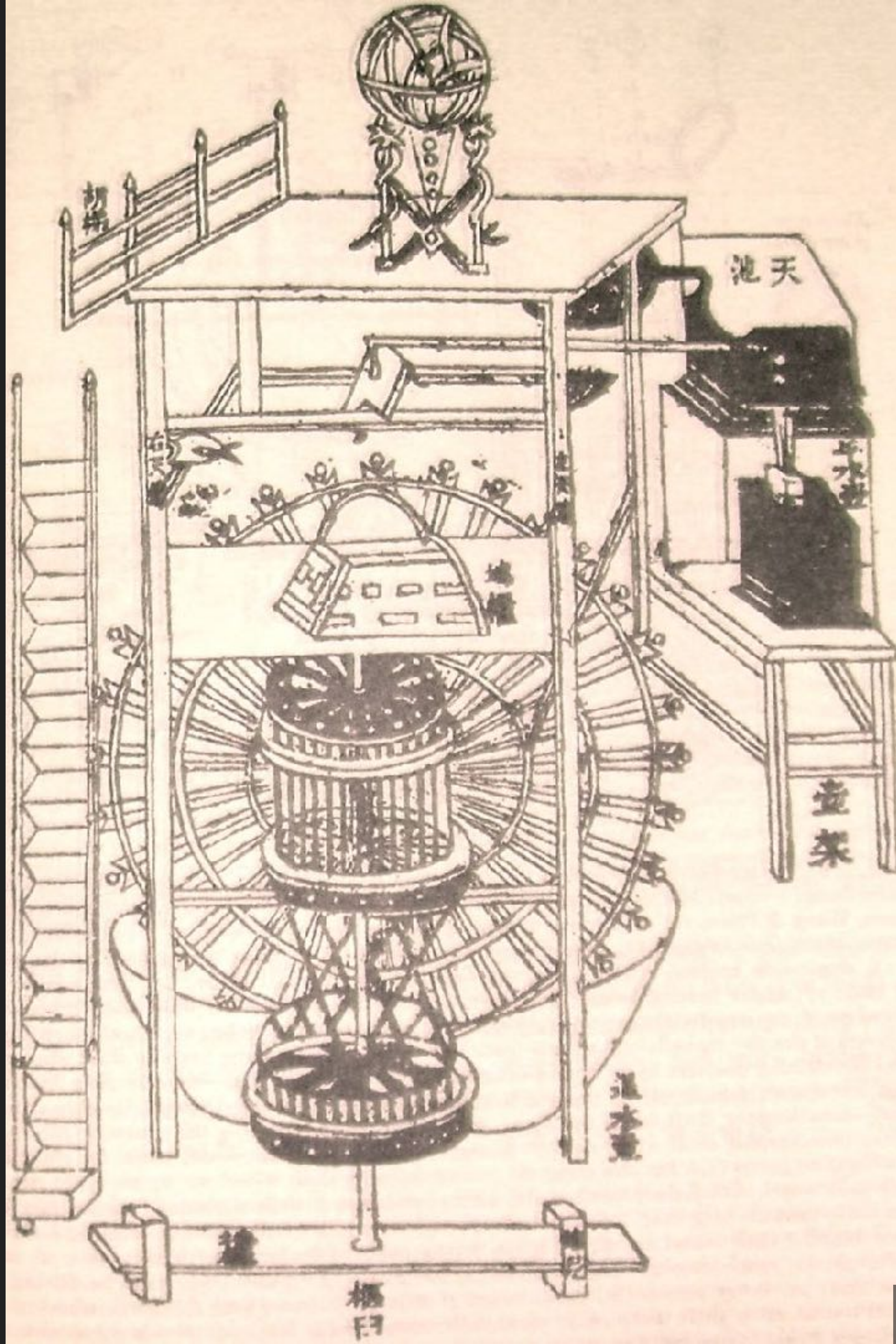



SU SONG ASTRONOMICAL WATER CLOCK

01094 CE, EARLY ESCAPEMENT

“Thus if the water is made to pour with perfect evenness, then the comparison of the rotary movements (of the heavens and the machine) will show no discrepancy or contradiction; **for the unresting follows the unceasing.**”

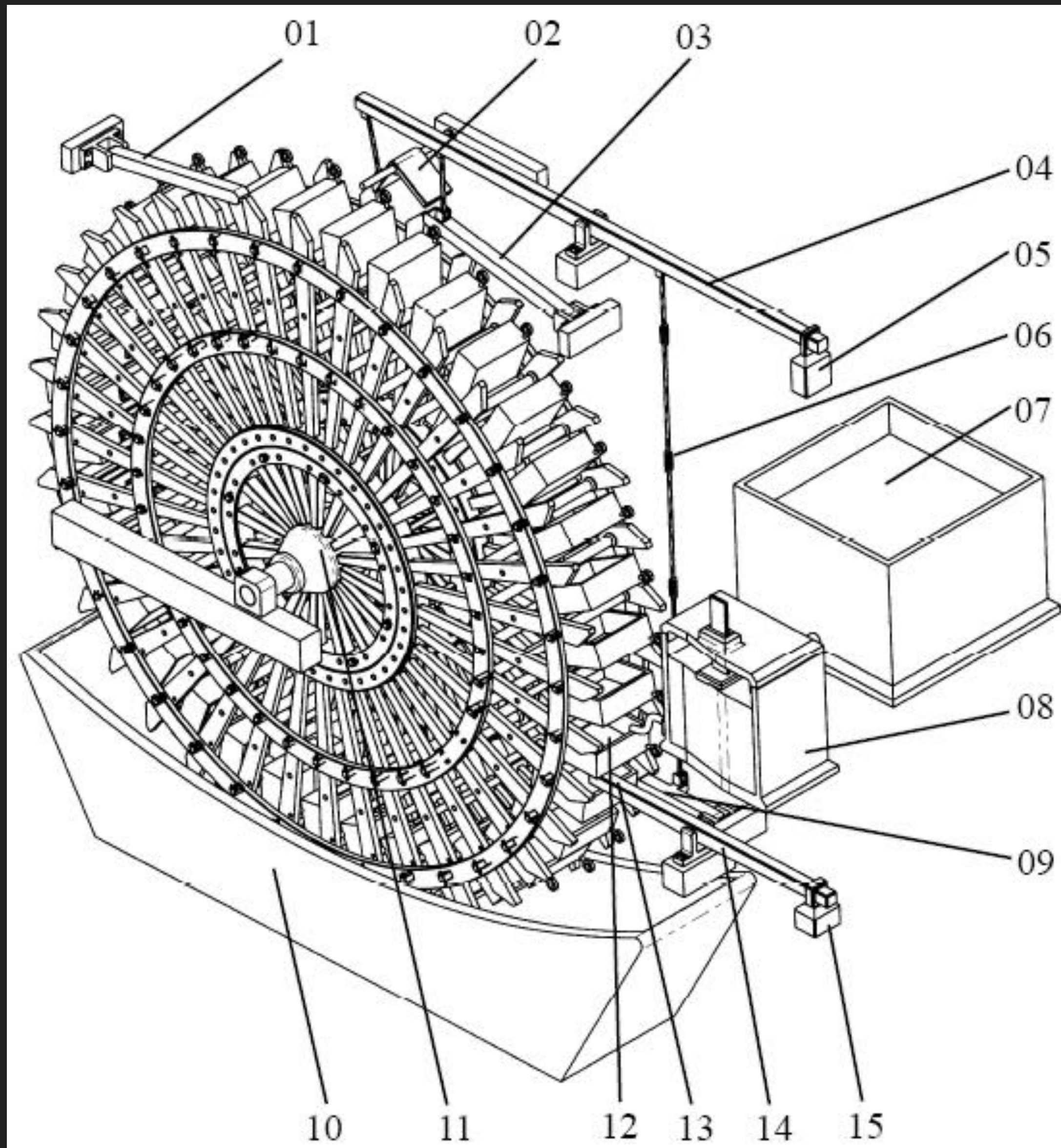
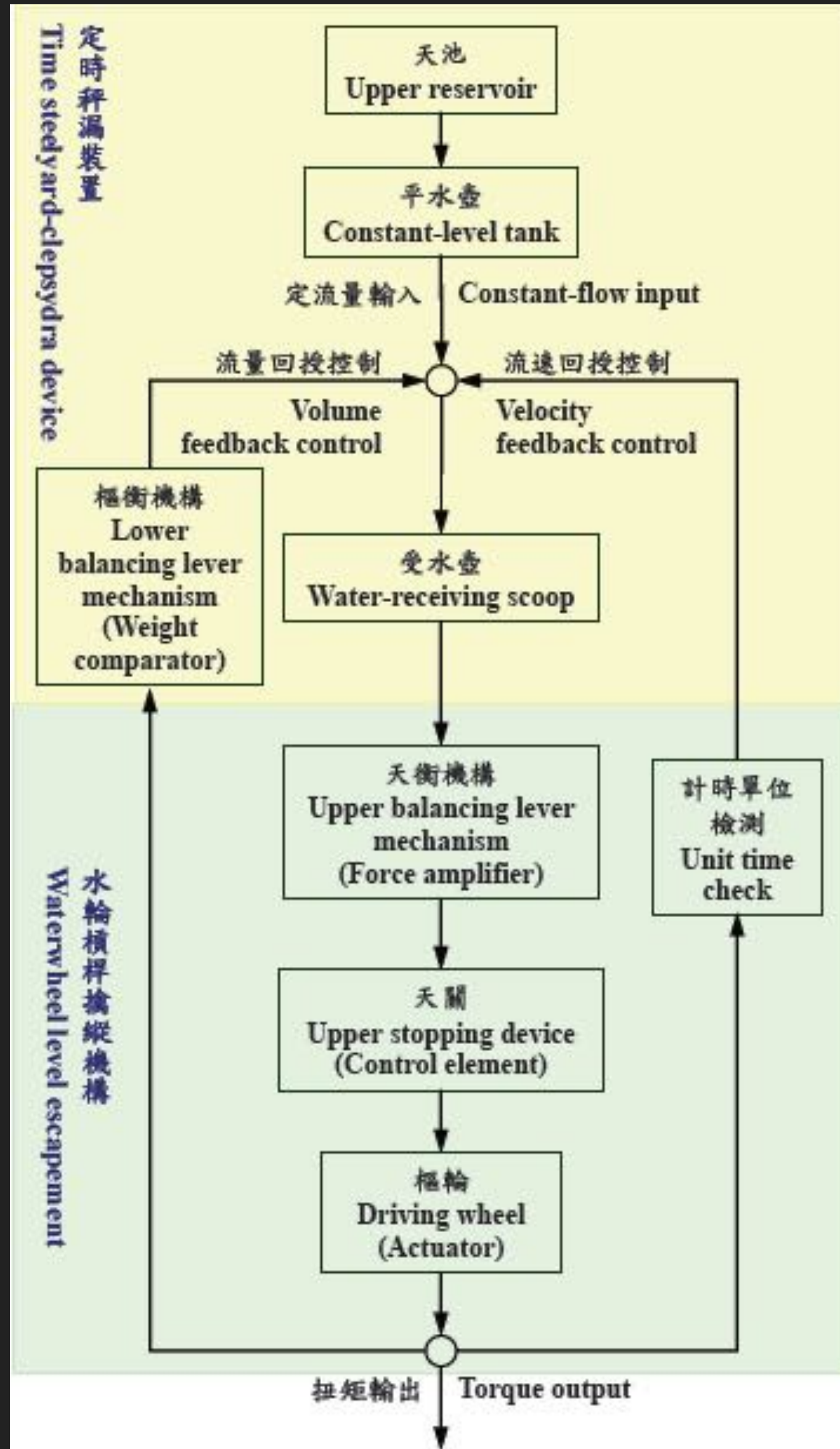

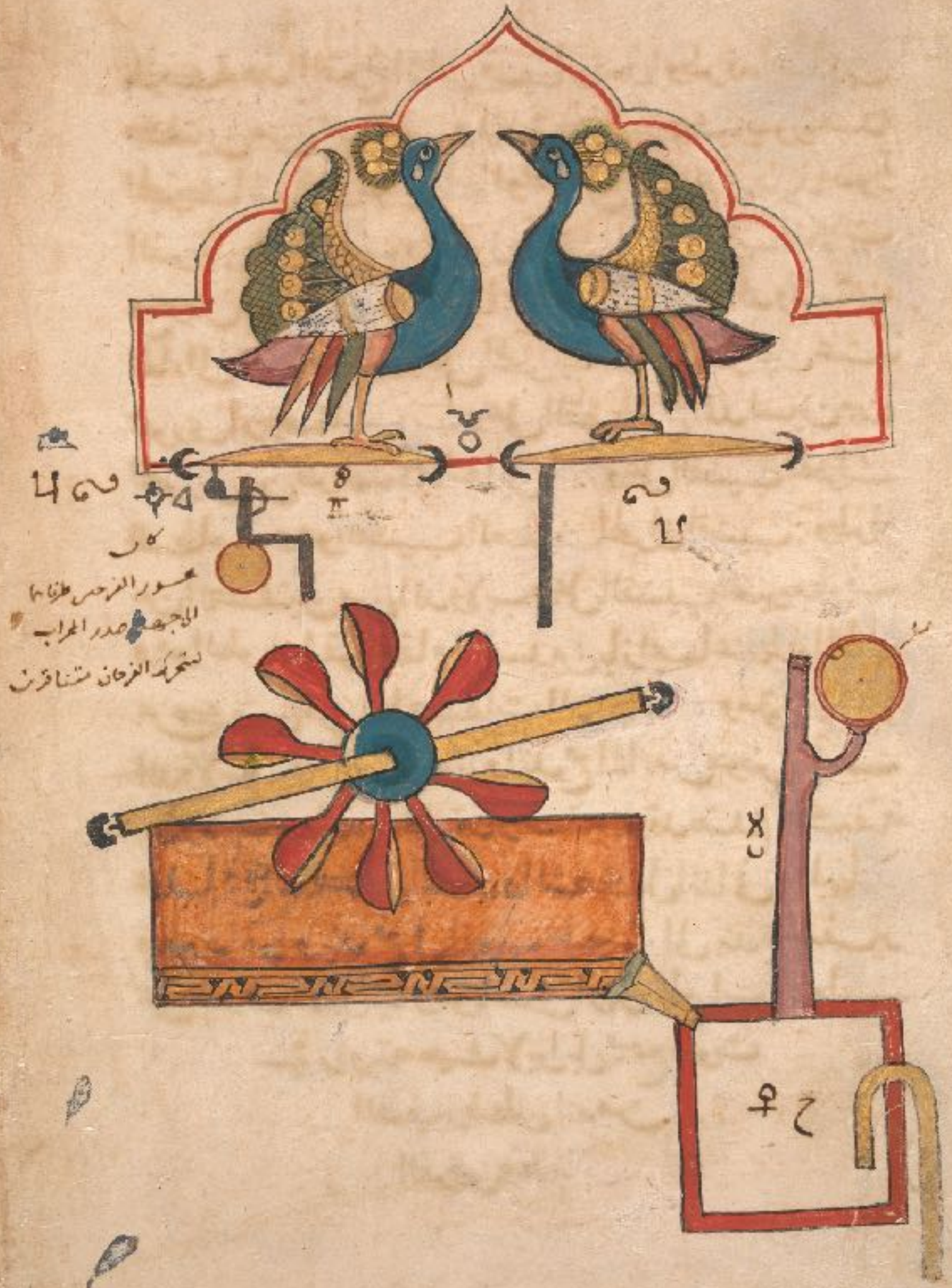

محور الزمان
الوجه صدر الحراب
لتحرك الزمان متناظر

الفصل

لحركة هذا الفرخ الثاني قضيباً واحداً وطرفه أيضاً بين
 كفتين من الدولاب وليعتمد على تشكيلة صورة هذه
 المحركات للفرخين فانها اوضح من الصورة وهذه صورة
 الفرخين في الحراب والمجاور والقضبان ودولاب الكفات
 وحوض تحته ومنه يخرج ما يقع على كفات الدولاب من
 الماء الى قدر الصفيرو وعلى الحراب **ا** وعلى الفرخين عند
 محوري ارجلها **ب** وعلى القضيبين المدلسين من
 المحورين من طرفهما الاسفلين **ج** وعلى القضيب المحرك
 للسطام **د** وهو القضيب المعطوف المحرك للقضيب **هـ** وطرفه
 بين الكفتين من الدولاب وعلى القضيب الغير معطوف
 وهو الطويل ليقوم مقام القضيبين بازايمها عند طرفه النازل
 بين كفتين من اعلى كفات الدولاب **هـ** ومتى دار هذا
 الدولاب تناقرا الفرخان وان دفع الماء من حوض تحت
 الدولاب وعليه **و** الى قدر الصفيرو وقد تقدم كيفية
 عملها في الشكل الاول والشكل الثاني وعليها **ز**
 فيطرد الهواء ويندفع في انبوب عليه **ح** الى بندقه صفيرو
 على طرف الانبوب وهو نافذ في ارض الحراب الاول
 في زاويته حيث لا يراى بل يسمع صوت
 الصفيرو فظن انه من
 الفرخين وعليه **ص**

"Design for the
 Water Clock of the
 Peacocks", from the
Kitab fi ma'rifat al-
hiyal al-handasiyya
 (Book of the
 Knowledge of
 Ingenious
 Mechanical
 Devices) by Badi'
 al-Zaman b. al
 Razzaz al-Jazari

1315 CE

ESCAPEMENTS

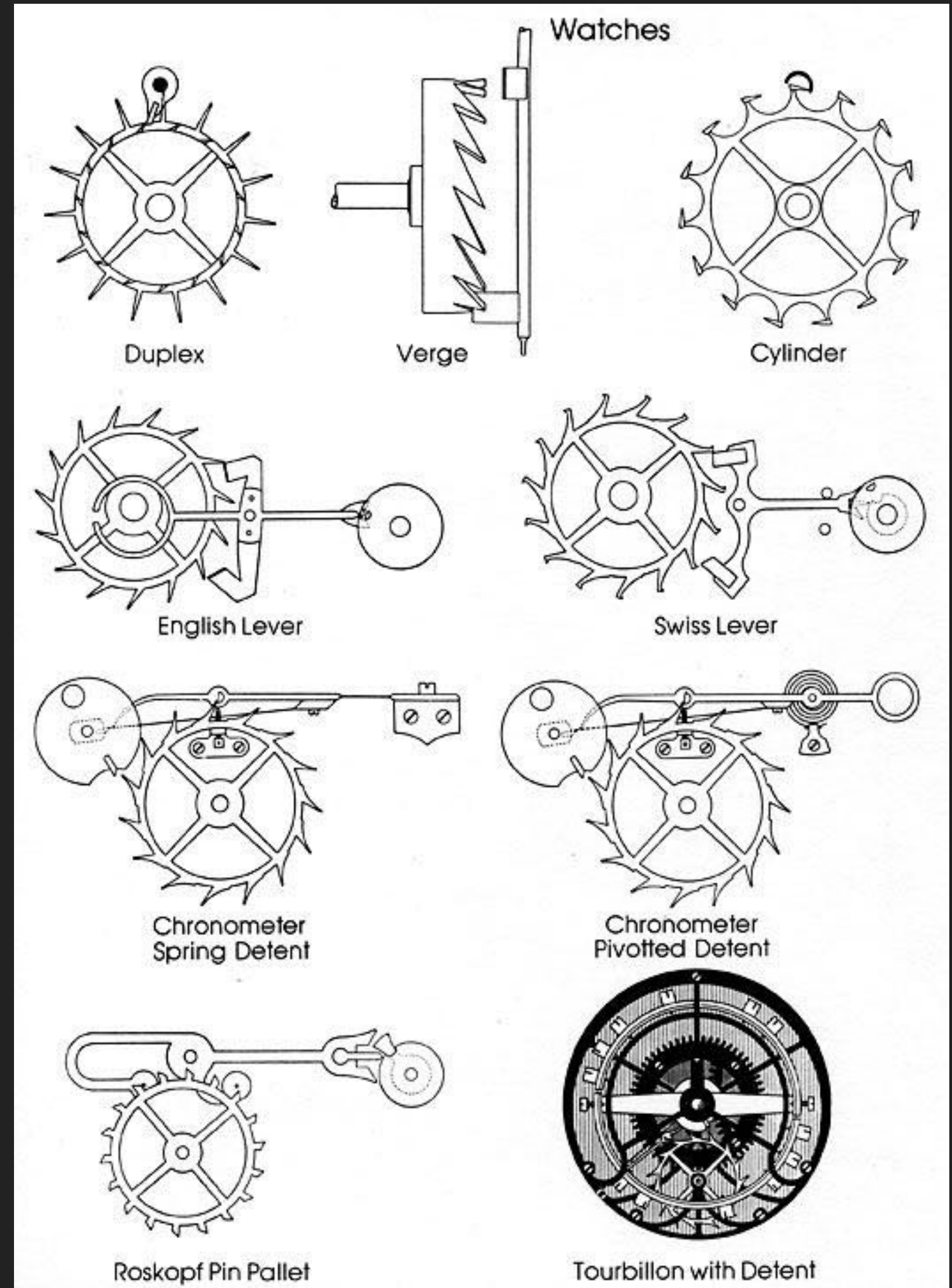
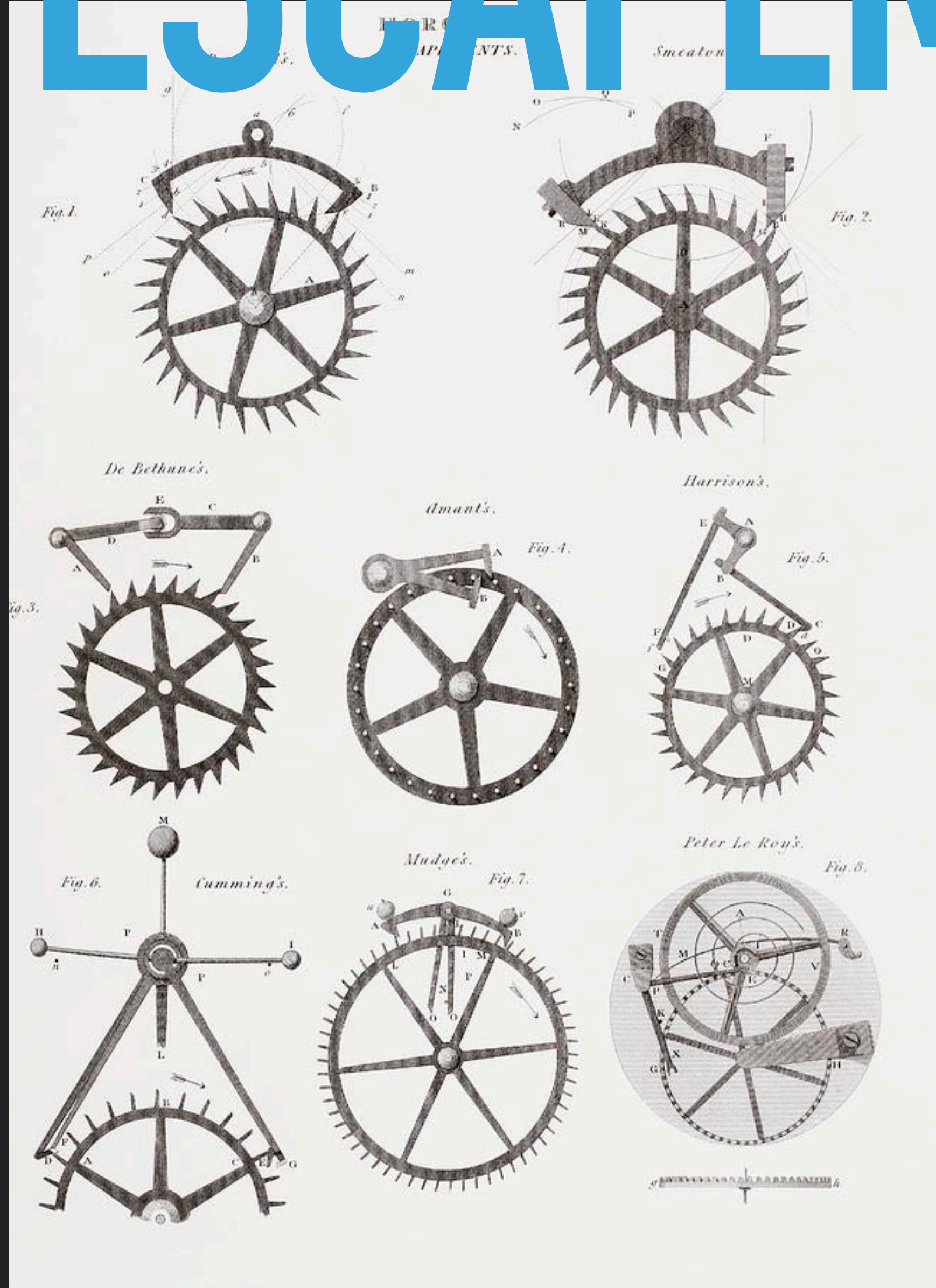

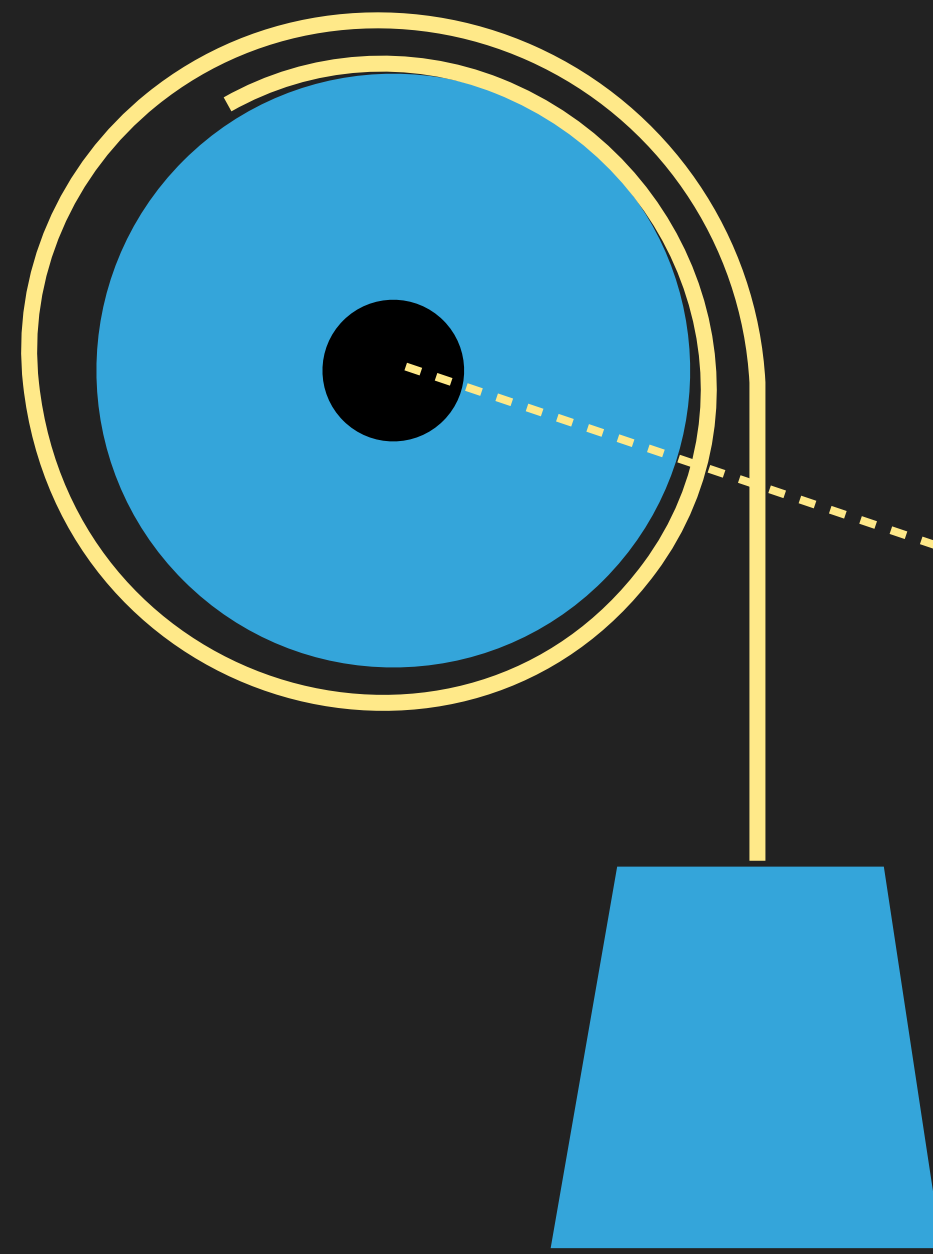

Energy: falling weight, wound spring

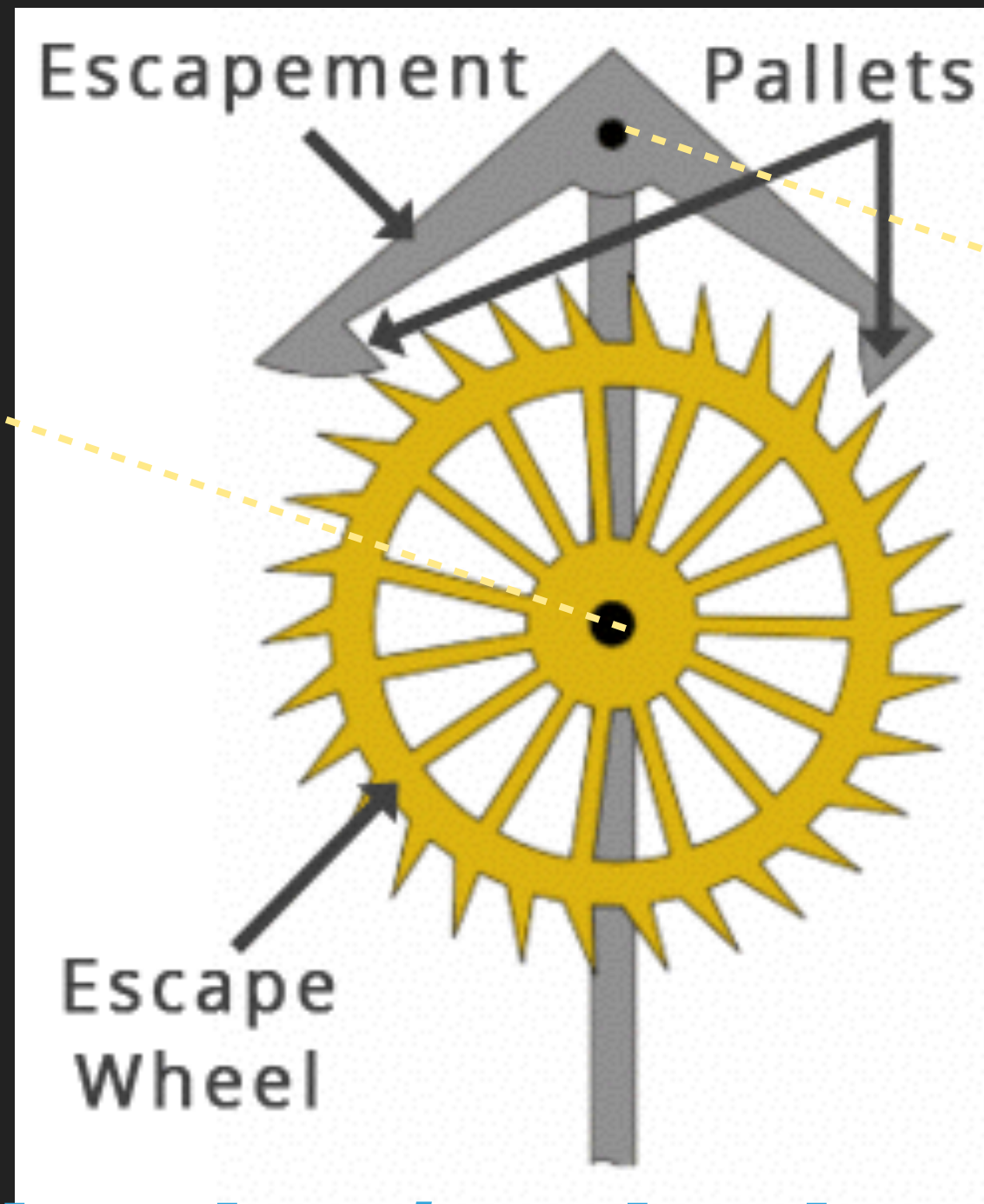

Locks / unlocks energy source; transfers energy to oscillator

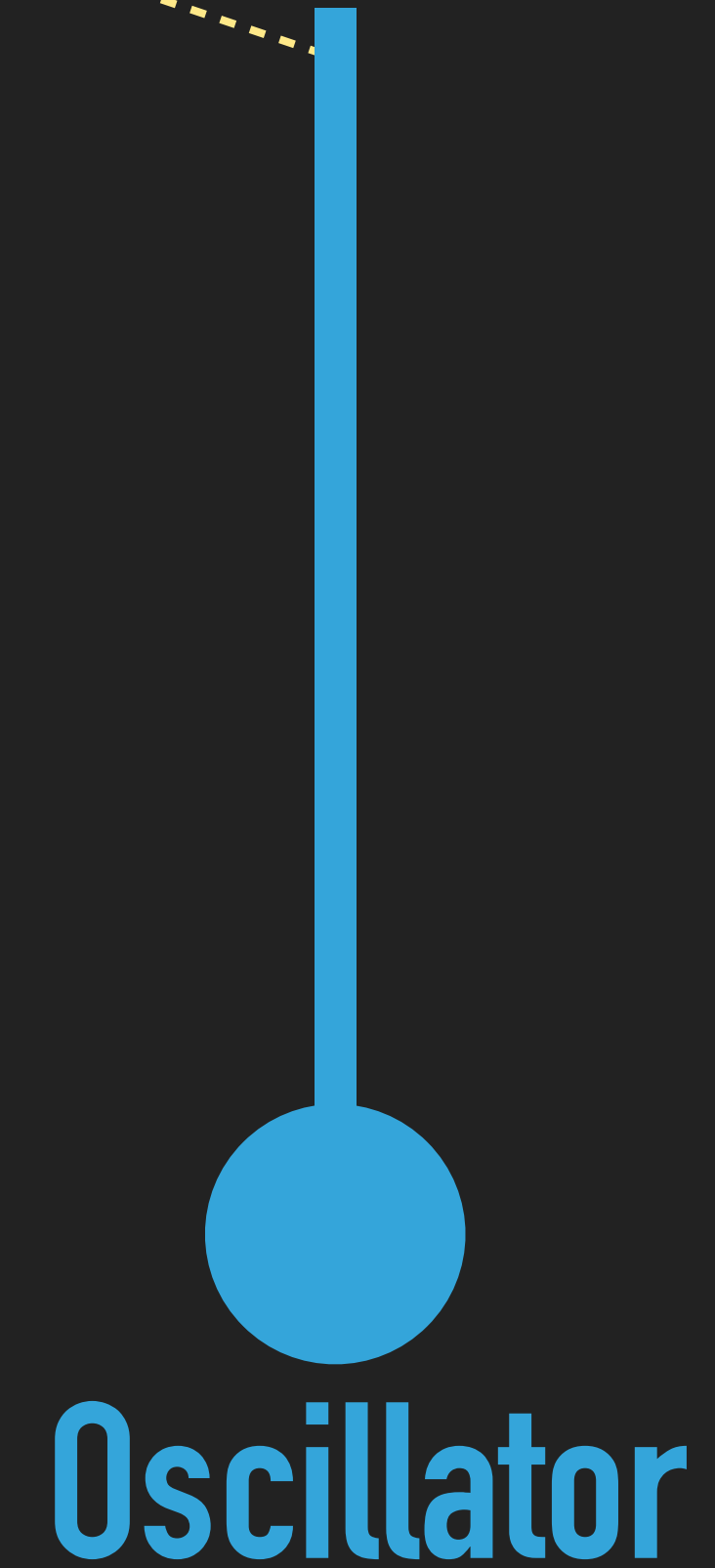

Oscillator

ESCAPEMENTS

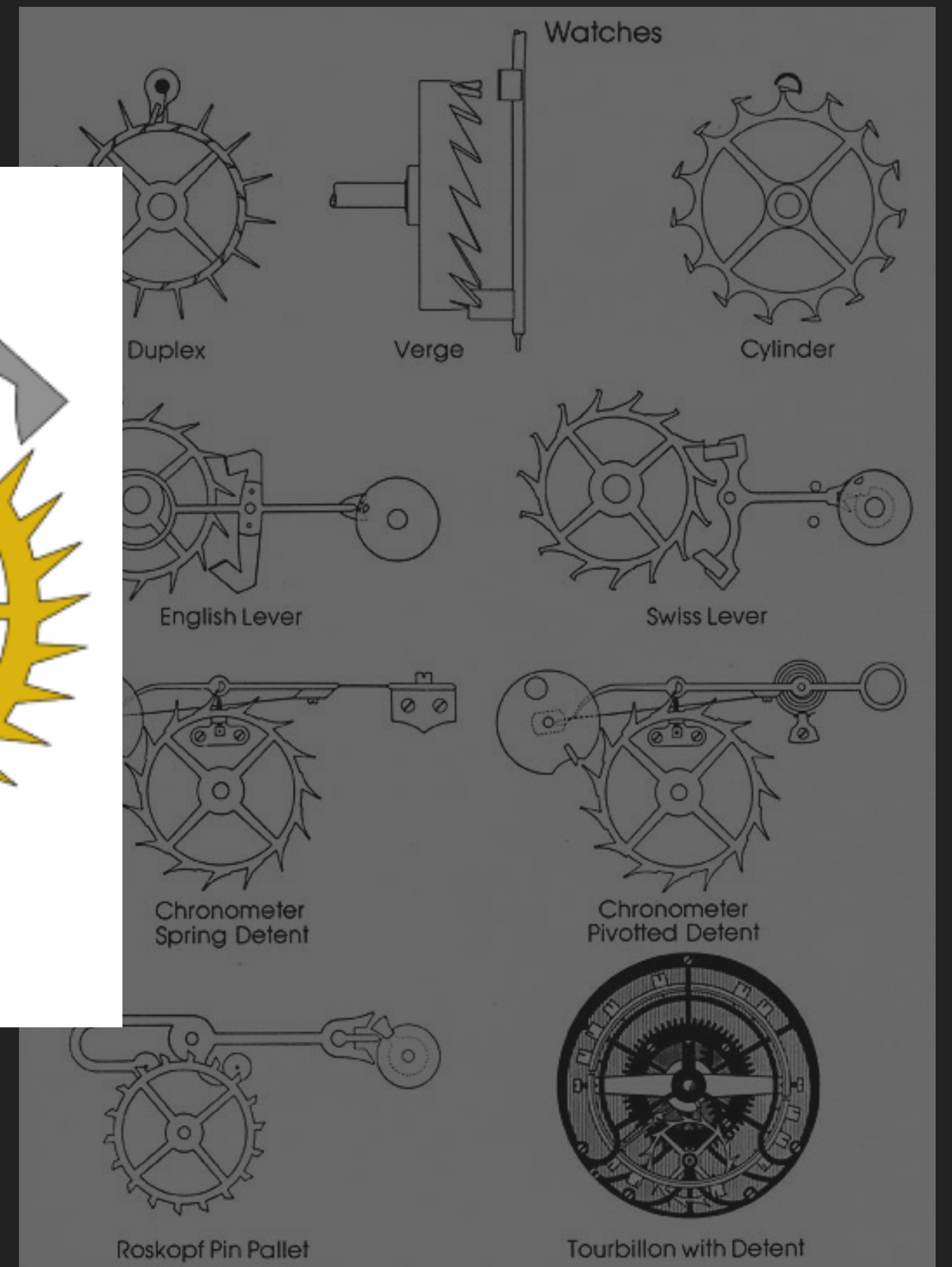
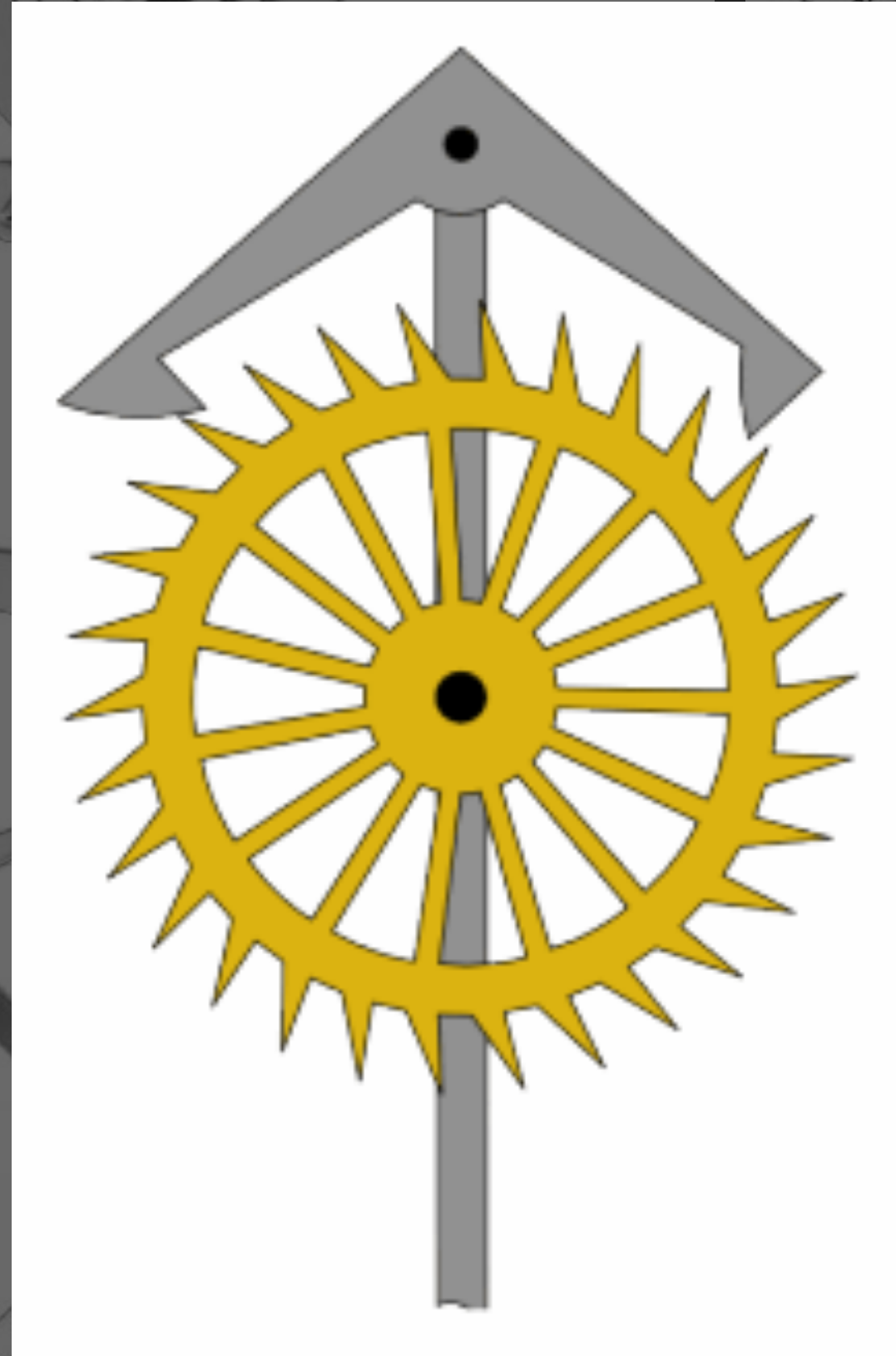
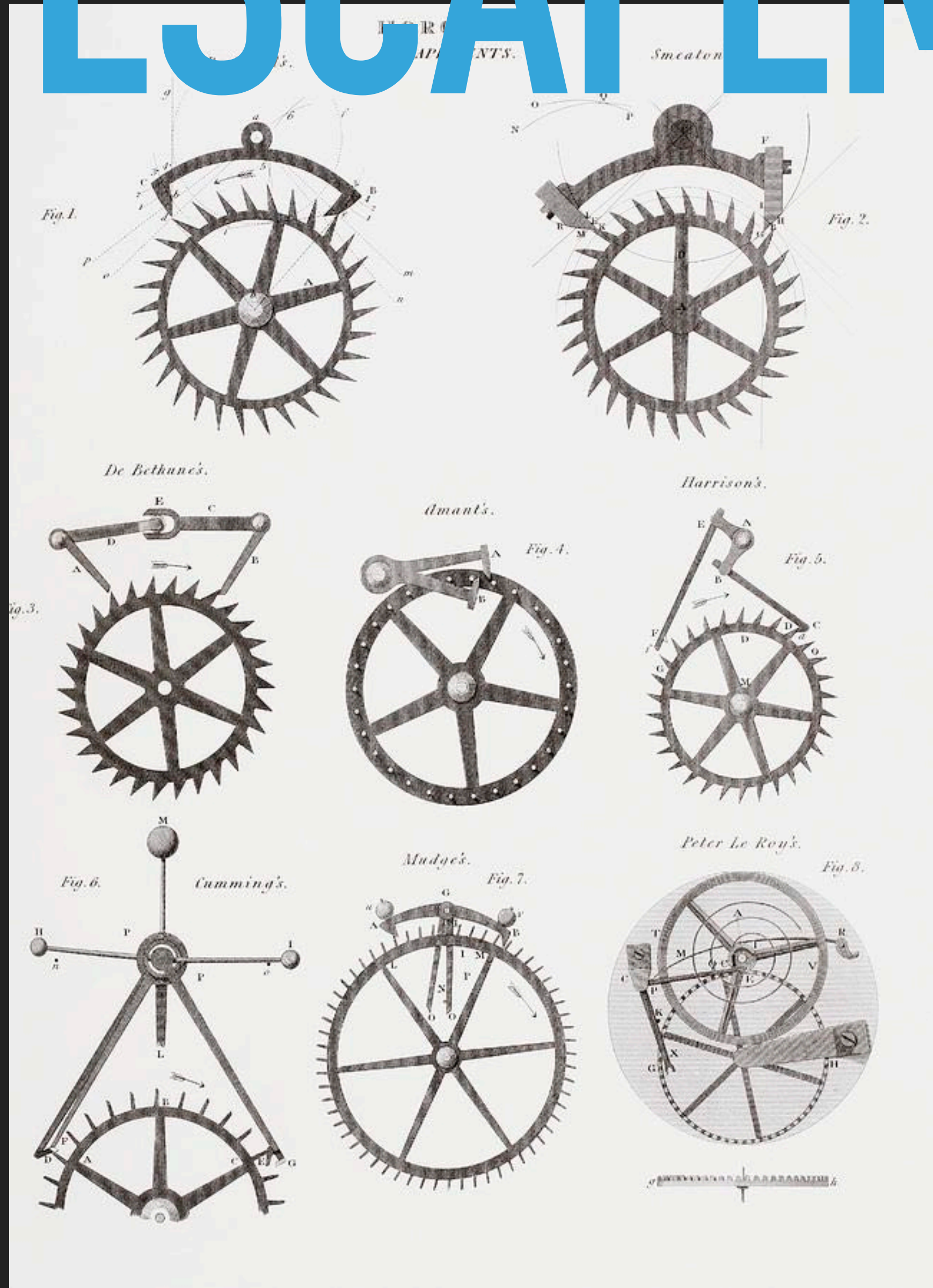

ESCAPEMENTS

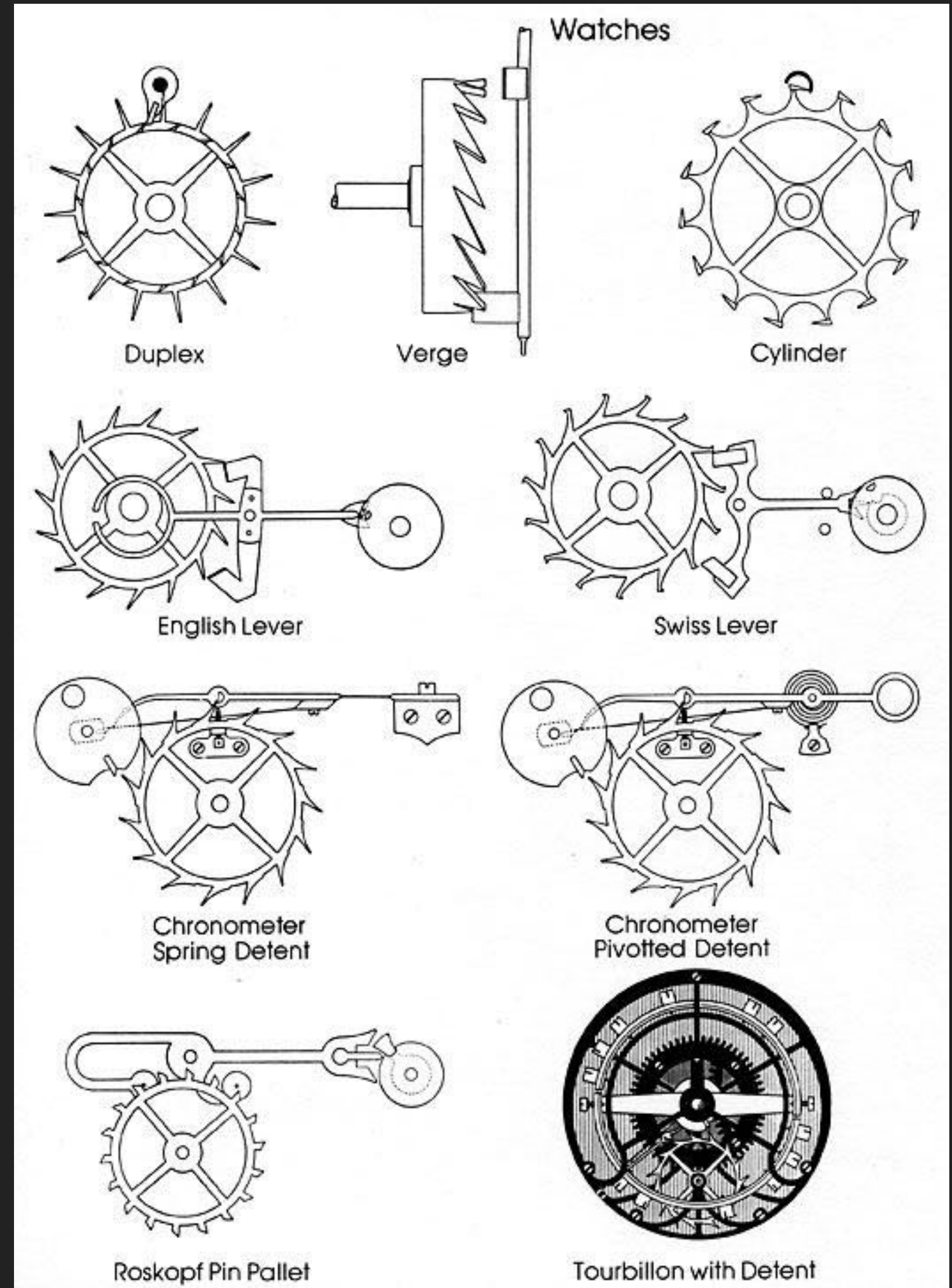
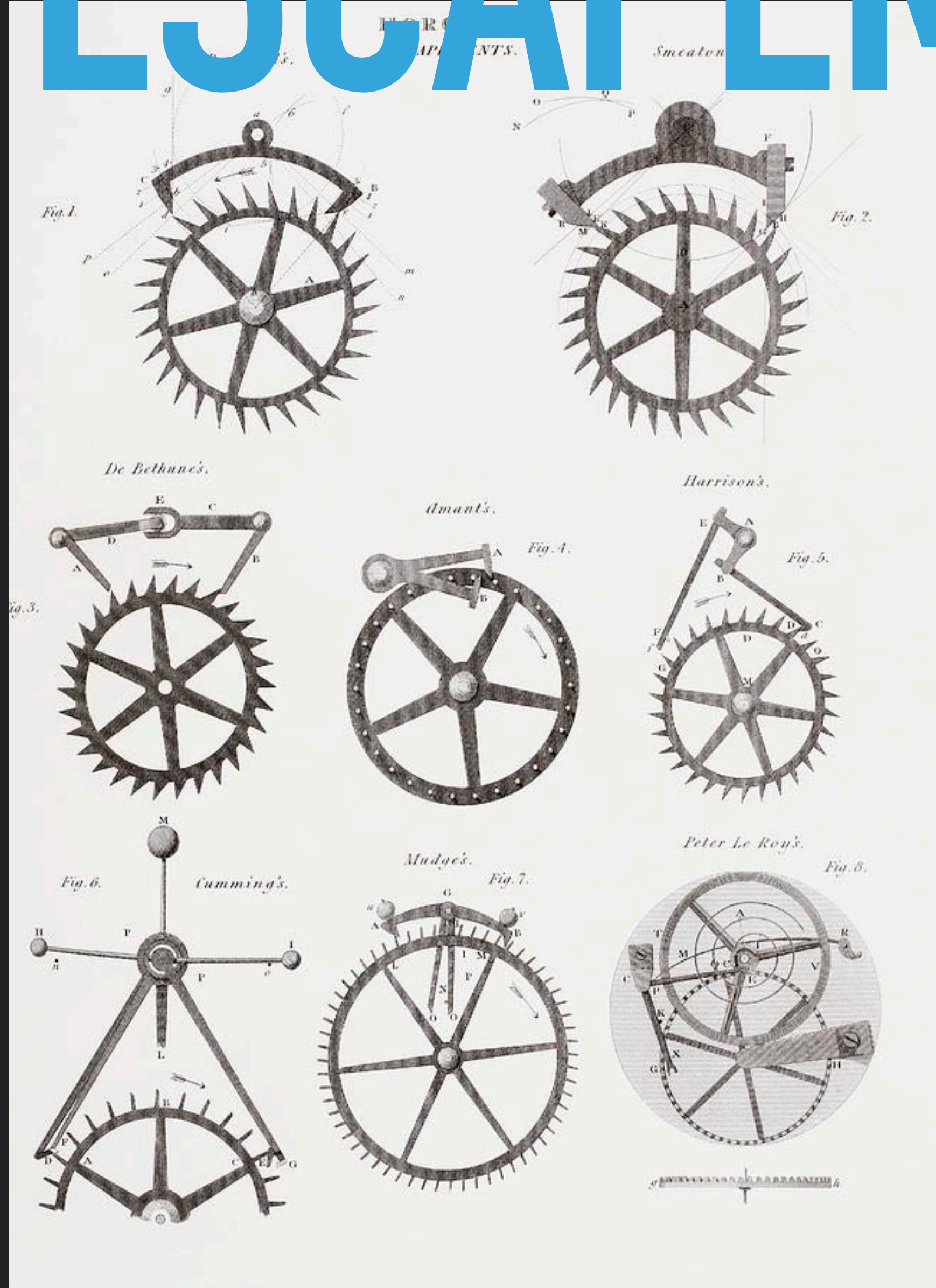

OSCILLATORS

Mechanical
40–208 BPM =
.67Hz – 3.5Hz



OSCILLATORS



Mechanical
~4-10 Hz

Last accurate, most expensive
Longest history, most repairable



Electromechanical
360 Hz

(No longer made)
Technological dead end, unrepairable

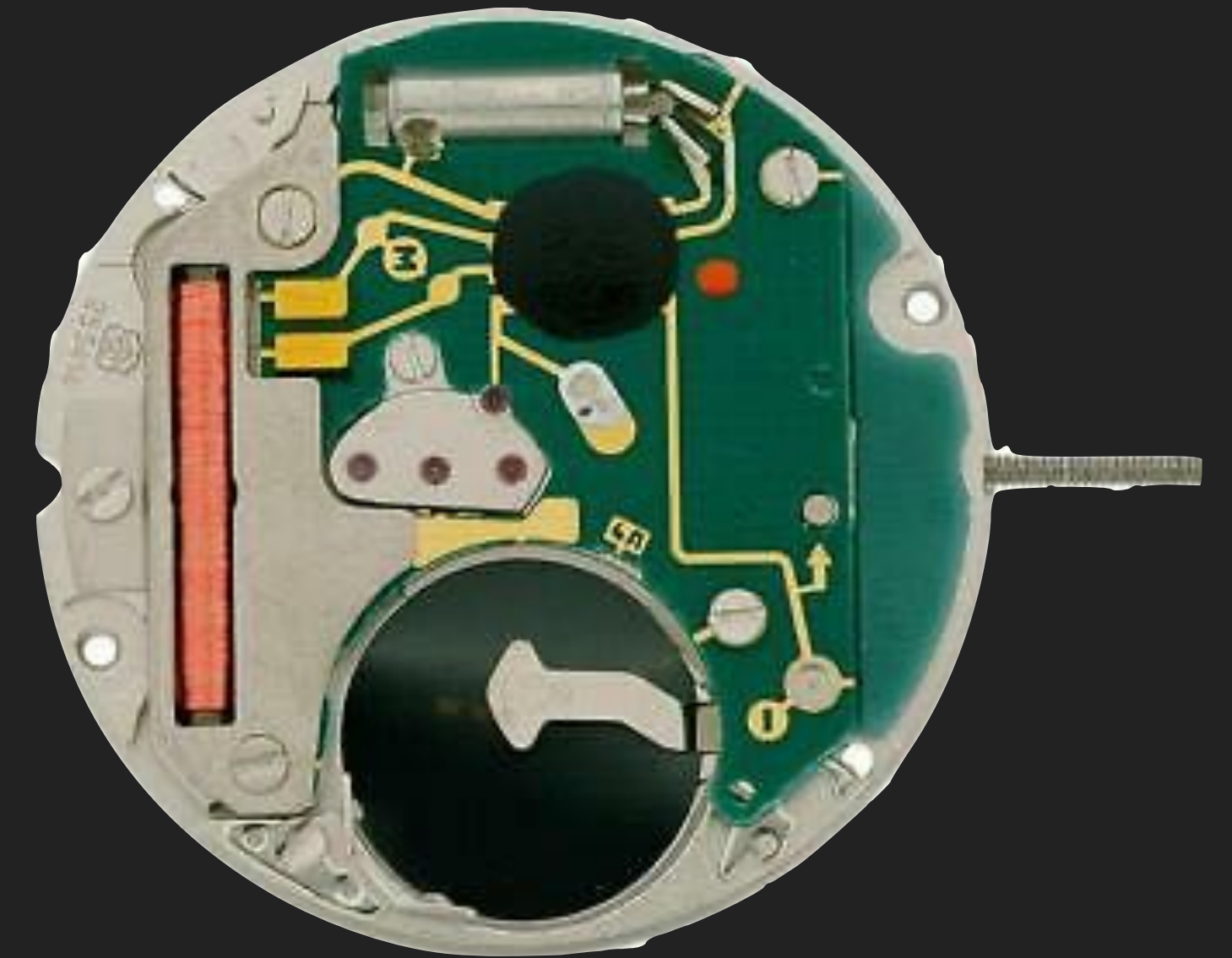

Quartz
32,768 Hz

Most accurate, least expensive
Unrepairable, common, disposable

OSCILLATORS

Mechanical
~4-10 Hz

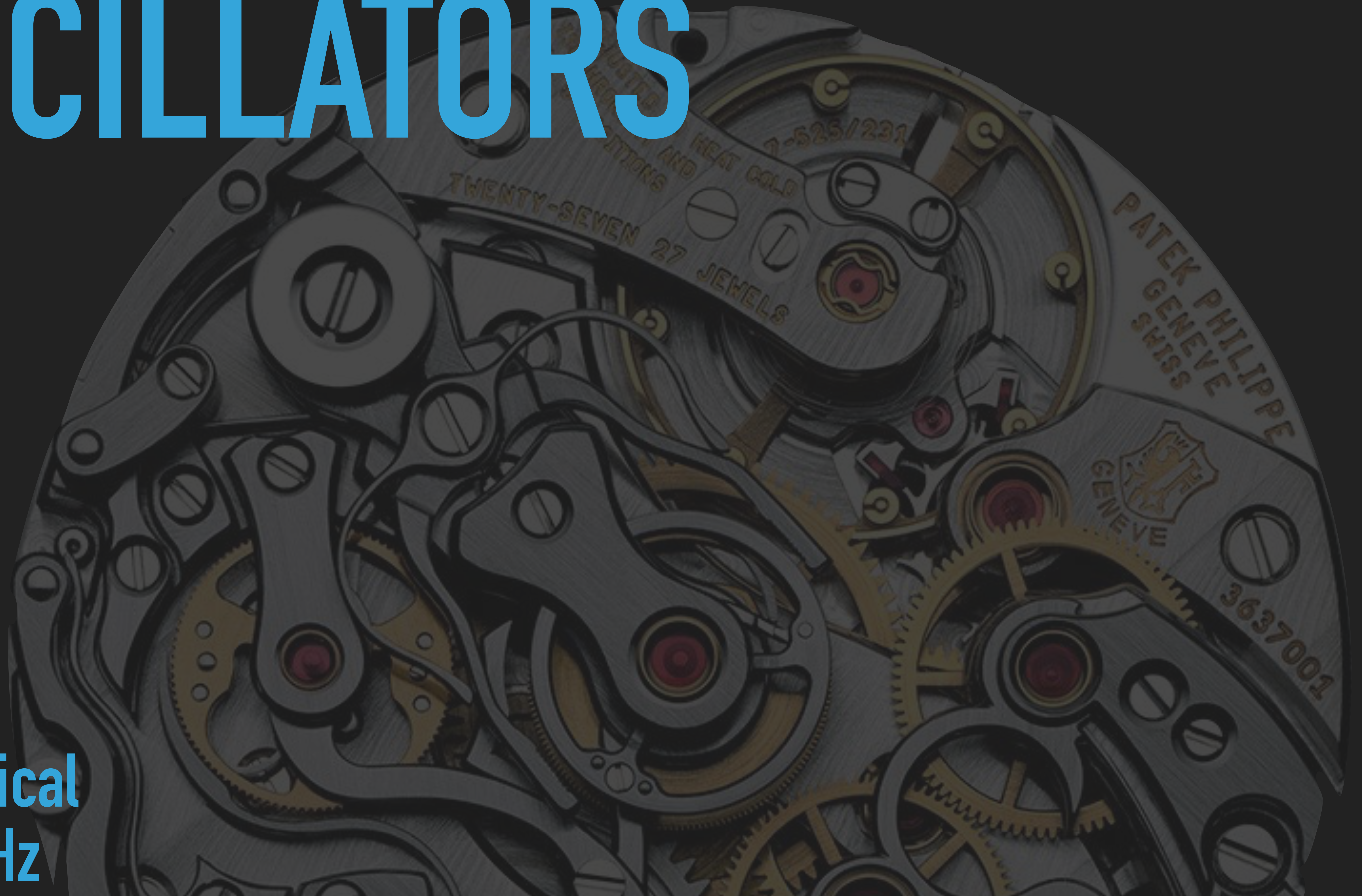

OSCILLATORS



SPRING

BALANCE WHEEL

ESCAPEMENT

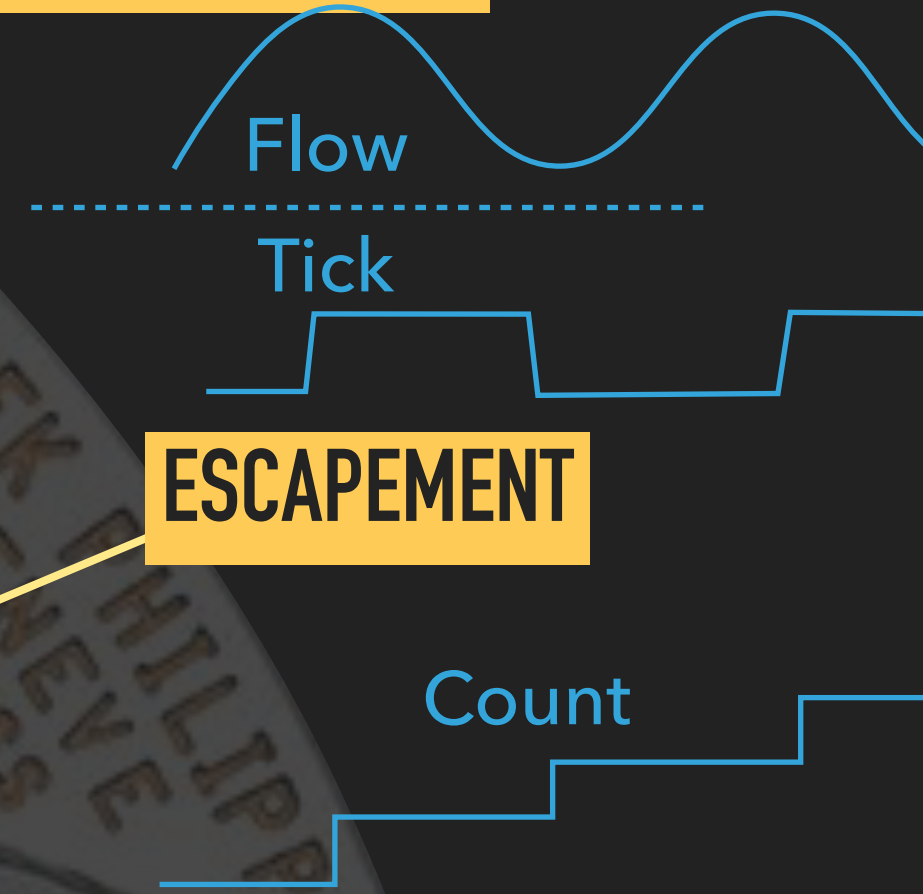

Mechanical
~4-10 Hz

(ASIDE)

Bulova Accutron tuning fork movement, 1960 - 1977

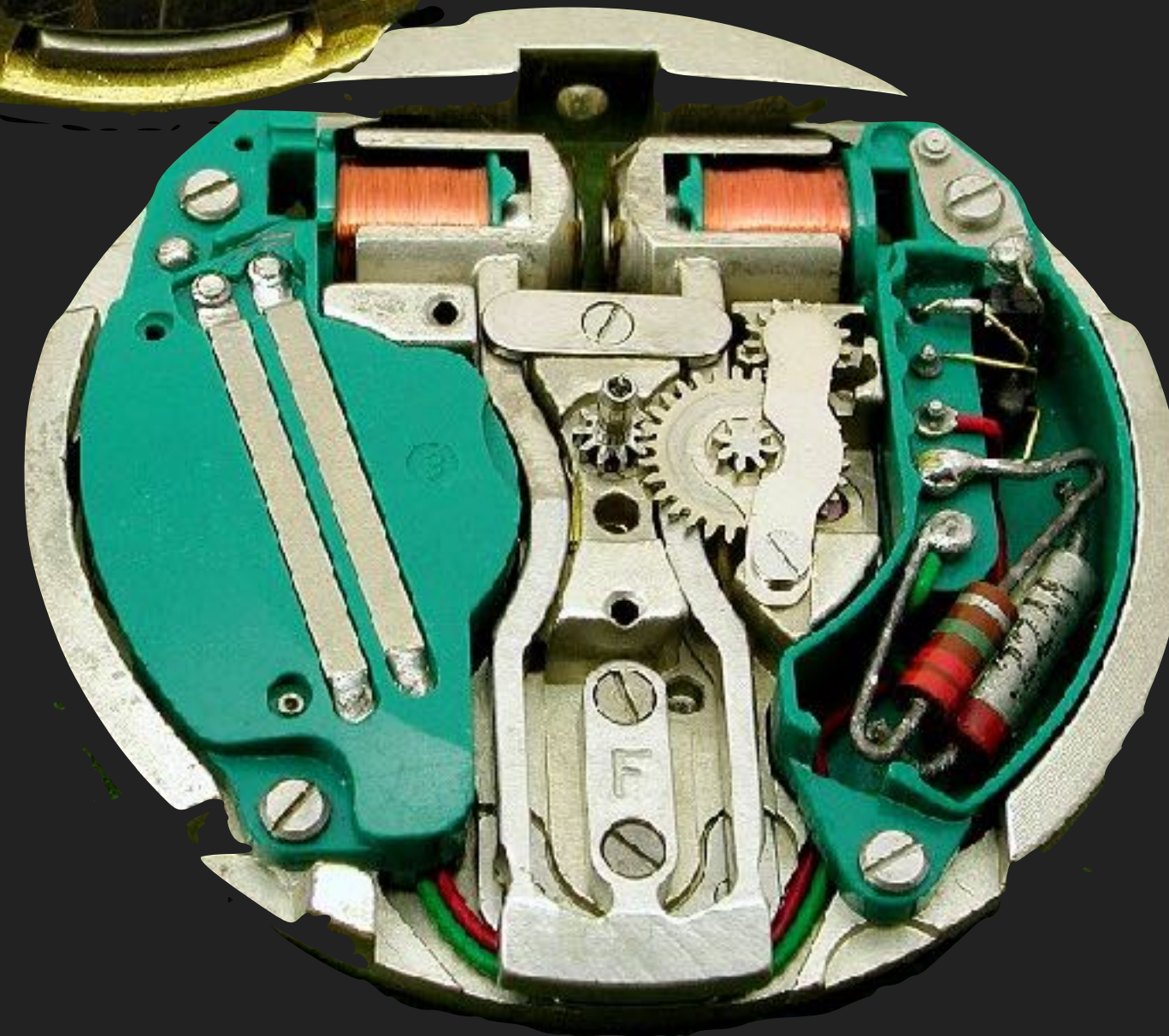

(AS)

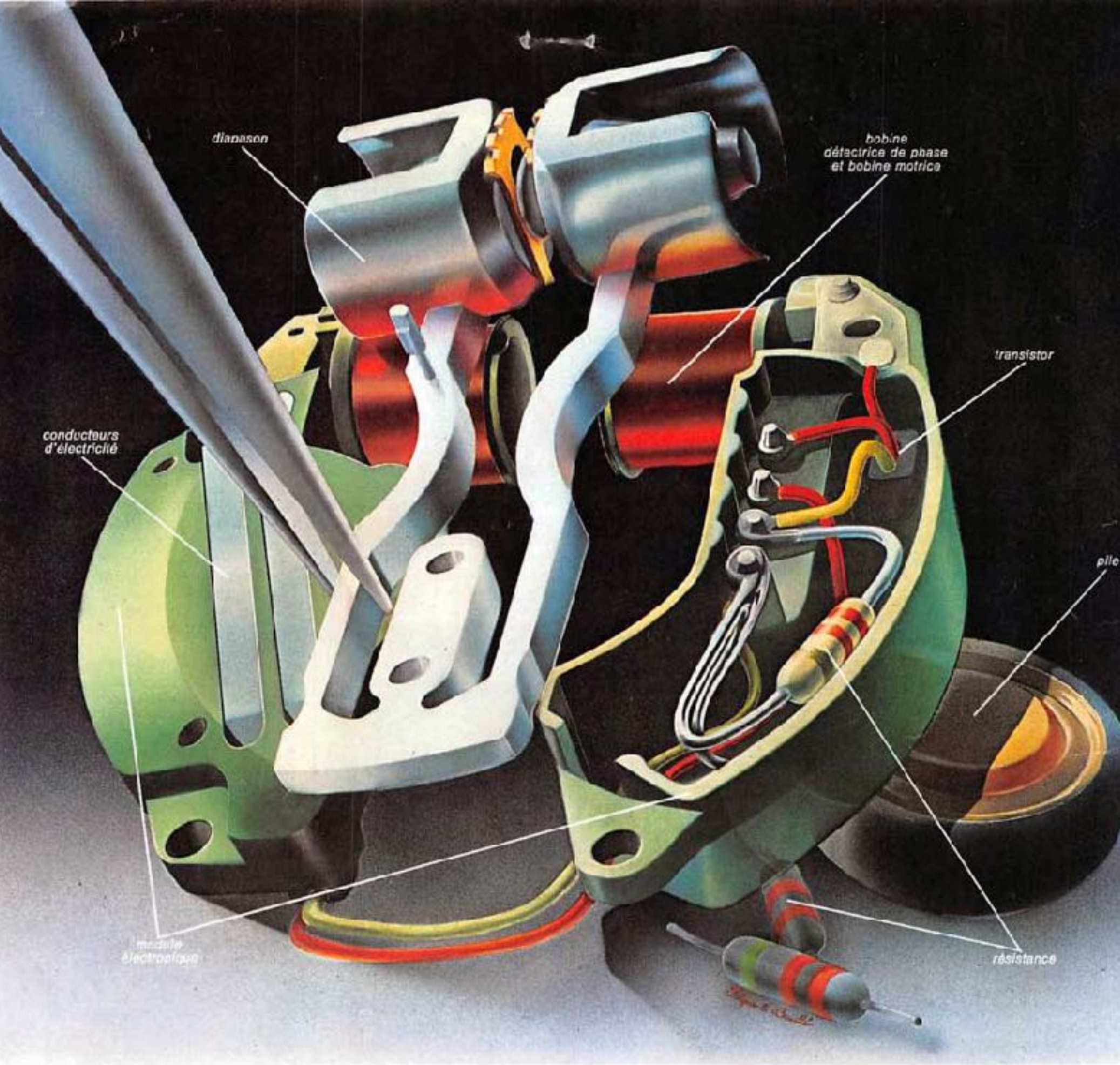
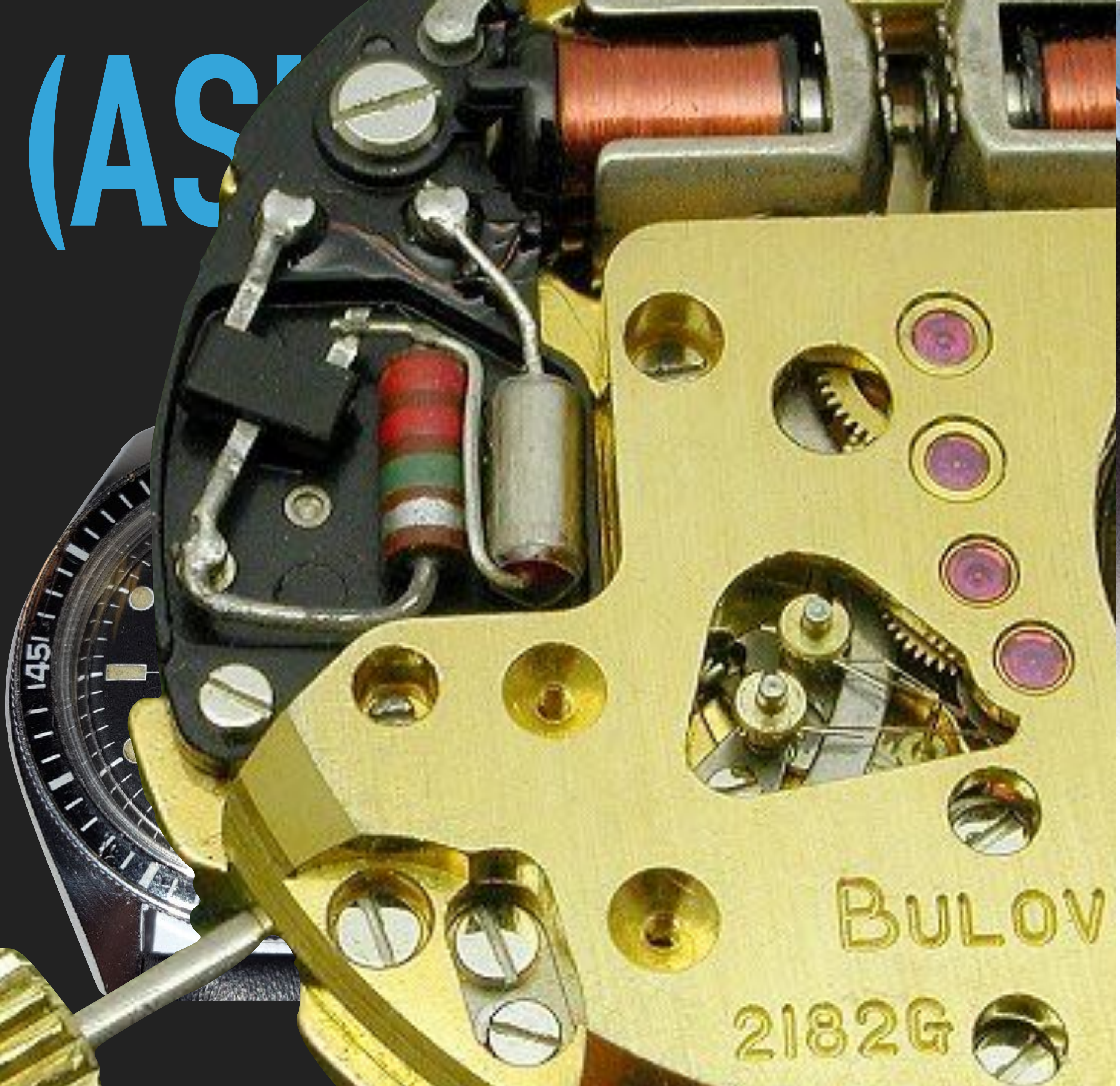

Bulova Accutron, première montre électronique à diapason.

L'électricité lui donne son énergie, l'électronique sa haute précision.

Dans une Bulova Accutron, l'énergie d'une pile est transmise à un diapason au moyen d'un circuit électronique intégré. Parce que l'énergie électrique n'a jamais été un facteur déterminant de précision, ce circuit électronique détecte et maintient à un degré constant la fréquence des oscillations du diapason (au moins 360 par seconde); ce qui permet d'obtenir au porter une



précision de 99,9977 % garantie par écrit. On est loin de l'«à-peu-près» d'un mécanisme traditionnel à balancier! Les deux montres ci-contre font partie des 100 modèles de la collection Bulova Accutron pour hommes et dames que vous trouverez chez tous les bijoutiers horlogers concessionnaires de la marque Bulova (à partir de 595 F)

BULOVA ACCUTRON
A chaque seconde, une certitude.

(ASIDE)



Me ~ 1979

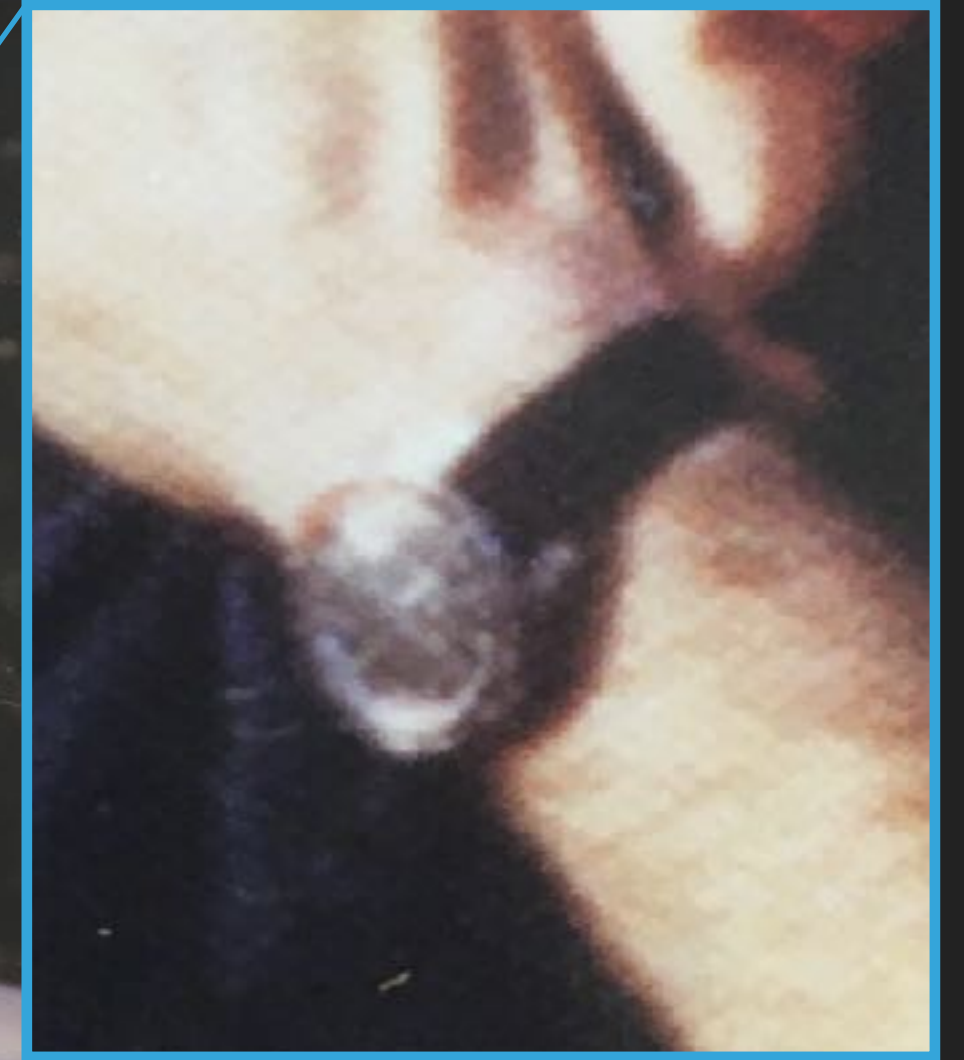

Super-Accurate Thousand-Dollar Quartz Watches... Now There's One Under \$200!

Here's the ultimate in timekeeping: Watches below are among the first models to appear in the U.S. Produced in limited quantity, all are slightly larger and heavier than conventional watches. Timex' new quartz was not available for this photo.



They hum like amplifiers, and their vibrating crystals insure accuracy of seconds a month

By OSCAR SCHISGALL

The most accurate timepiece ever devised by man. That's how watch makers describe the newest thing in timekeeping: the electronic quartz watch. Some also call it "the most important new way of measuring time developed in more than 200 years."

Sound wild? It's not an exaggeration. The electronic quartz concept is so different and important that the watch industry may never be the same again.

Big problem with quartz watches until now: They're terribly expensive.

The first models coming out of Switzerland and Japan start at \$595 in stainless steel, go up to \$2,200 in gold. That's why they've been manufactured in limited quantities and only a few have been sold. Now Timex has announced a new model scheduled to go on sale late next month. The price, as of this writing, is estimated at somewhere between \$150 and \$185.

What's an electronic quartz watch? How does it differ from others? How good is it? Let's take these questions one at a time.

The quartz watch is based on a principle entirely different from those of all other watches. Most watches rely on the familiar balance wheel. A carefully balanced spring-driven wheel rocks back and forth at a rate (usually five times a second) determined by its size and weight. The accuracy with

which it maintains that base rate largely determines the watch's accuracy. A top-quality balance-wheel movement keeps accurate time to within perhaps four minutes a month. The tuning-fork concept is more sophisticated. The tuning fork, much like the one the piano tuner uses, vibrates or oscillates 360 times per second; and it results in a watch that's accurate to within a minute a month.

The quartz watch completely abandons the mechanical time-regulating device—balance wheel or tuning fork. Instead, it uses an electronic oscillator much like the one that controls the frequency of a broadcast station. The frequency of this oscillator—exactly as in a radio station—is determined by a bar-shaped sliver of quartz. Most quartz watches use quartz oscillators

Continued

There are at least two reasons why the Timex is so much cheaper — advanced

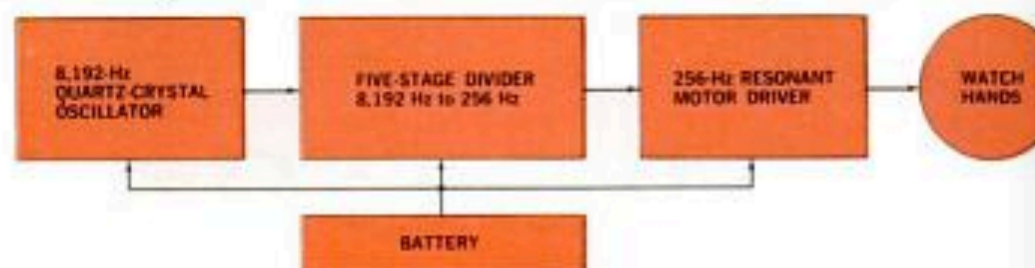
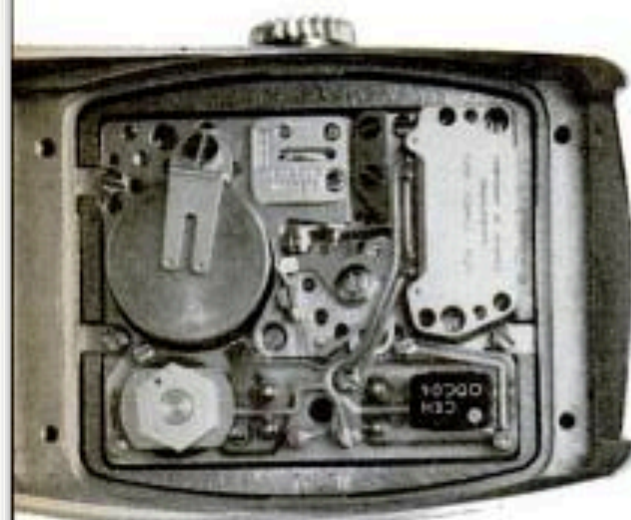

SWISS-CEH The Swiss Center of Electronic Horology developed this quartz watch for its member companies, among them Bulova and Omega. The 8,192-Hz quartz oscillator goes through a five-stage divider in a micro-electronic integrated circuit. The resulting output is 256 Hz. This frequency goes to an

electromagnetic motor which further divides the pulse into one-second intervals. Using this pulse, the wheel train turns the hands. Omega's integrated circuit contains 21 transistors and 61 other electronic elements. Member companies in the CEH or organization may alter the basic movement slightly to fit an individual watch case.

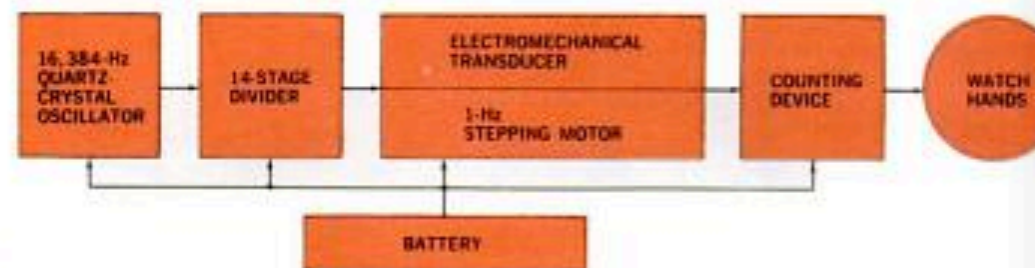
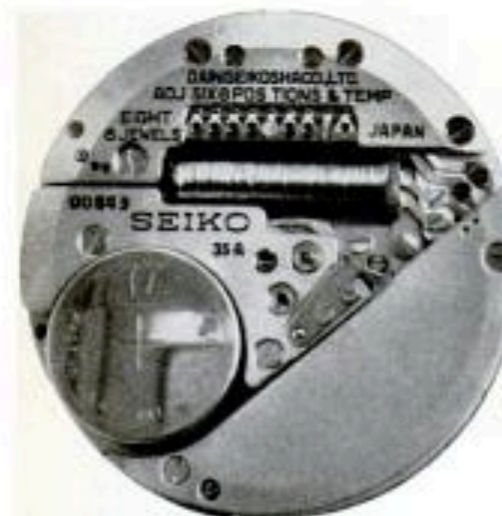

SEIKO This quartz has five major components: 16,384-Hz quartz-crystal oscillator circuit, integrated circuit with an electromechanical transducer, and silver-oxide battery. The divider circuit halves the 16,384-Hz frequency 14 times (8,192; 4,096; etc.—down to a single pulse).

The electromechanical transducer convert the one-pulse signal into mechanical motion, to turn the six-pole stepping motor in 60-degree increments. Finally, the counting device moves the second hand at exact one-second intervals. Pulling out the crown stop the second hand, for precise control. Battery life is claimed to be one year.

with 8,192 Hz—vibrations per second. If you listen to a quartz watch, it hums like a tuning fork—but it's far more accurate.

Quartz, the familiar transparent crystalline mineral, is a remarkable substance. It has piezoelectric characteristics. If a voltage is applied across a slab of quartz, it bends slightly. Put the quartz in an oscillator circuit and it will vibrate at its natural frequency, which is determined by its size and shape.

This natural oscillation frequency is so precise that quartz watches are accurate to within seconds per month. Most quartz-watch makers guarantee accuracy to within five seconds a month; the Timex people conservatively claim an accuracy of 15 seconds a month.

How they work. Most quartz watches operate on the same general principle. (Longines work differently; Timex, we can't say.) First, you have a quartz-crystal oscillator circuit. Next, a small mercury or silver oxide battery to provide voltage so the quartz can oscillate. But the quartz crystal's natural vibrating frequency is too high; more manageable speeds

are needed to move around the hands.

Micro-electronic integrated circuits come in here. "Dividers" in these circuits "step down" the frequency by halving it several times (8,192 frequency is the 13th power of 2—2¹³). The number of dividers in the circuit depends on the quartz-crystal frequency and other circuitry a particular company uses.

Whether the pulse is divided down to one pulse or a slightly higher frequency (256 in the Swiss movements), an electro-mechanical motor receives the pulse and converts electrical energy to mechanical energy. This drives the wheel train that eventually turns the hands. Of course, each company's watch works a little differently. (See explanations above.)

Still, the big mystery is why the Timex is so much cheaper—between a third and a quarter of the price of its nearest competitor. Undoubtedly, there are at least two reasons.

First, a technology geared to enormous production. "We have developed mass-production techniques unmatched outside the United States," says Joakim Lehmkuhl, president of Timex. "You can't produce 19 million

mass-production technology and a circuit that's still top secret

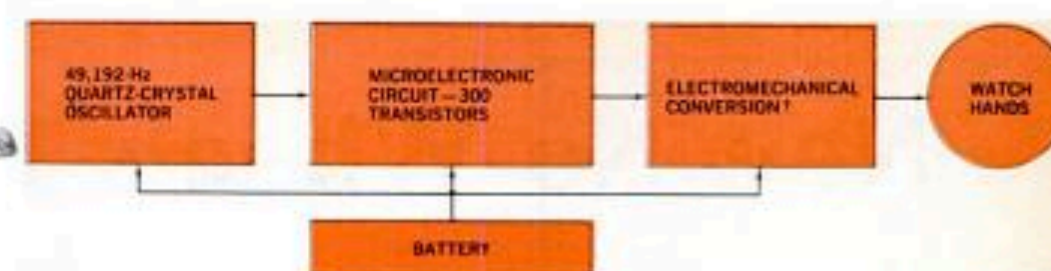

TIMEX What's inside? We don't know yet. At press time the technical information was still "top secret." We do know that the Timex movement uses a crystal oscillator with a 49,192-Hz frequency—far higher than any other quartz on the market. This frequency is not a power of two as in the others—which makes it even

more mysterious. It has a micro-electronic circuit—about one centimeter square—containing 300 transistors. It also uses a silver-oxide battery good for a year. It could have several things in it—including some kind of comparison circuit, or a digital or analog means of controlling the watch's speed. It's accurate to 15 seconds a month.

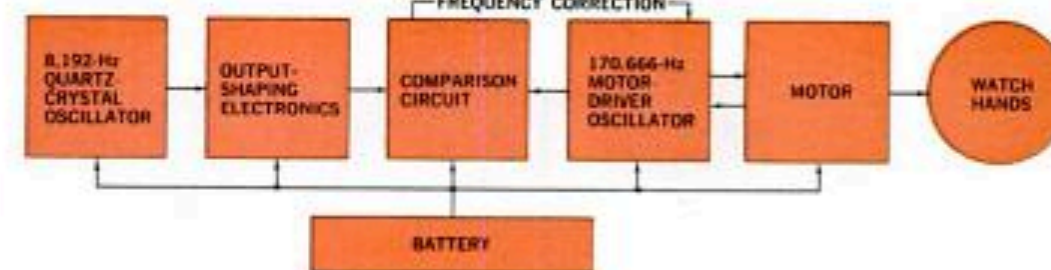
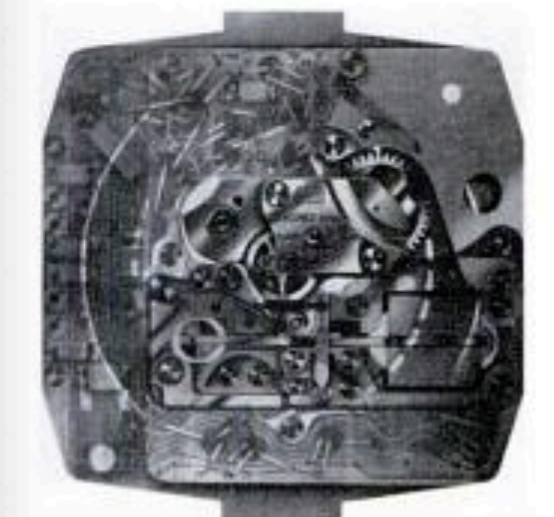

LONGINES This one's unique: A comparison circuit detects error in the watch's output and self-corrects. A 9,192-Hz quartz oscillator is the frequency reference—which is not divided, as in other watches. A 170-Hz servomotor, independent and operating by itself, turns the hands. Mechanical output is compared

with the quartz signal. If there's an error signal in the comparison circuit, a correction is applied to the motor. If motor frequency and crystal frequency are in step, the error signal is zero. The circuit has 14 transistors, 19 resistors, and seven capacitors. Insurance against loss or theft for one year comes with the watch.

high frequency. The company has apparently made an important breakthrough in quartz-watch technology—one that gives it a tremendous advantage—and company engineers and executives are understandably reluctant to reveal their secret.

Although the Timex people showed me various versions of their watch, they refused permission to photograph it—face or movement. Nevertheless, Timex executive vice-president Robert Mohr did give POPULAR SCIENCE some exclusive technical information, emphasizing that "our watch, as far as I know, is entirely different from any other quartz watch." This, along with our speculation of what's inside it, is above.

How about watch performance? Reliability? "Since there are virtually no moving parts," says Lehmkuhl, "very little can go wrong. We have put the watch through every conceivable test of temperature, altitude, and humidity. We have made every test for position error—dial up, dial down, three o'clock up, six o'clock up, nine o'clock up. Where we found bugs we corrected them."

And shock and water resistance?

"Water resistant, yes. As for being shock resistant..." Lehmkuhl smiled. "It is sturdy, but we don't recommend that you hurl it against walls as we did in torture tests with our conventional watches. We wouldn't recommend such treatment for any item that costs over \$100."

In any event, Timex seems destined to be the first to market the new watch in quantity, and Seiko threatens to be a close second. Why aren't the Swiss (such as Bulova, Omega, Longines, and others) marketing quartz watches in large numbers?

Tuning-fork watches. Bulova has had a lot of success with its Accutron tuning-fork watch. Now other Swiss companies have been licensed by Bulova to make tuning-fork watches. As one Swiss manufacturer said, "We want to make the most of our tuning-fork watch, which represents a heavy investment. Time enough for the quartz watch when the tuning-fork has passed the peak of popularity."

Another predicted differently. "Timex and its advertising campaign for the quartz watch may well be the catalyst that will compel all of us to jump in and compete."

I asked Joakim Lehmkuhl of Timex how far away he thought the era of the quartz watch might be.

"We don't expect a hundred million Americans to throw away their watches tomorrow morning in order to buy a quartz watch. We are dealing not only with watches, but with human nature. We expect, as new watches are bought, that purchasers will want the latest and most accurate type. Simply because the quartz watch is unquestionably the newest and most accurate example of horology man has so far achieved, we are confident that it will be, if not the dominant watch of tomorrow, surely that of the day after tomorrow."

And what can we expect, the day after that? Nuclear timekeeping. Some day you may be able to buy a watch containing a milligram of an alpha-particle-emitting radioactive isotope as a power source. It may be accurate to within a few seconds a year—almost as accurate as the movement of the Earth itself! Although Bulova's engineers are already exploring nuclear timekeeping, they believe it's a long way off. Name? What else but the atomic watch? □

Super-Accurate Thousand-Dollar Quartz Watches...

Now There's One Under \$200!

Here's the ultimate in timekeeping: Watches below are among the first models to appear in the U.S. Produced in limited quantities, they are slightly larger and heavier than conventional watches. New quartz was not available for this photo.

\$1,325



They hum like amplifiers, and their vibrating crystals insure accuracy of seconds a month

By OSCAR SCHISGALL

The most accurate timepiece ever devised by man. That's how watch makers describe the newest thing in timekeeping: the electronic quartz watch. Some also call it "the most important new way of measuring time developed in more than 200 years."

Sound wild? It's not an exaggeration. The electronic quartz concept is so different and important that the watch industry may never be the same again.

Big problem with quartz watches until now: They're terribly expensive.

Micro-electronic integrated circuits come in here. "Dividers" in these circuits "step down" the frequency by halving it several times (8,192 frequency is the 13th power of 2— 2^{13}). The number of dividers in the circuit depends on the quartz-crystal frequency and other circuitry a particular company uses.

Whether the pulse is divided down to one pulse or a slightly higher frequency (256 in the Swiss movements), an electro-mechanical motor receives the pulse and converts electrical energy to mechanical energy. This drives the wheel train that eventually turns the hands. Of course, each company's watch works a little differently. (See explanations above.)

The quartz watch completely abandons the mechanical time-regulating device—balance wheel or tuning fork. Instead, it uses an electronic oscillator much like the one that controls the frequency of a broadcast station. The frequency of this oscillator—exactly as in a radio station—is determined by a bar-shaped sliver of quartz. Most quartz watches use quartz oscillators

oscillation frequency of quartz watches are in seconds per month. Watch makers guarantee within five seconds a day accuracy of 15 seconds

Continued

There are at least two reasons why the Timex is so much cheaper — advanced

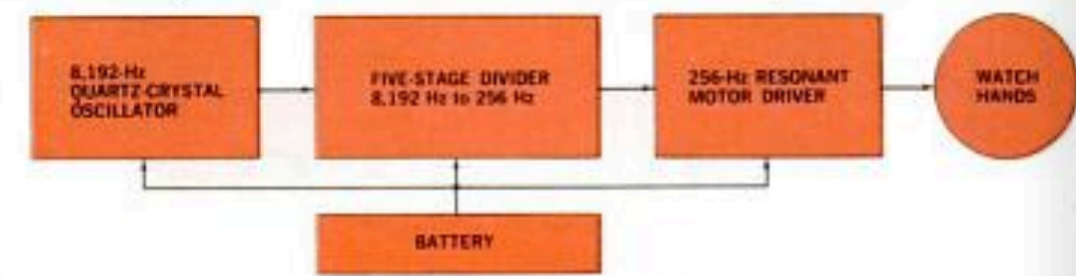
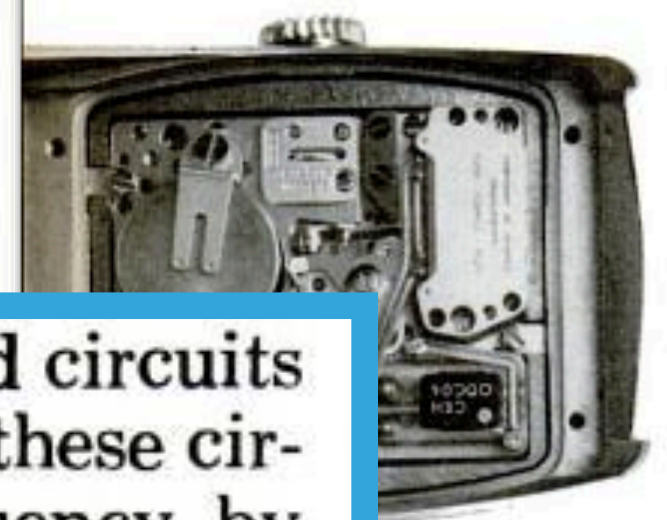

SWISS-CEH The Swiss Center of Electronic Horology developed this quartz watch for its member companies, among them Bulova and Omega. The 8,192-Hz quartz oscillator goes through a five-stage divider in a micro-electronic integrated circuit. The resulting output is 256 Hz. This frequency goes to an

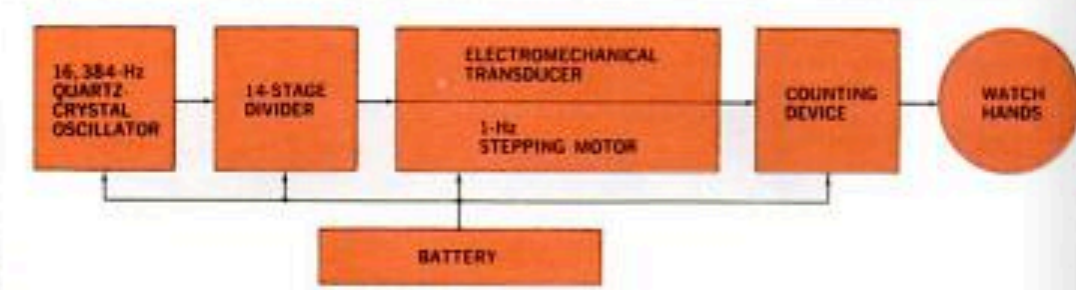

SEIKO This quartz has five major components: 16,384-Hz quartz-crystal oscillator circuit, integrated circuit with an electromechanical transducer, and silver-oxide battery. The divider circuit halves the 16,384-Hz frequency 14 times (8,192; 4,096; etc.—down to a single pulse).

ibrations per second. a quartz watch, it ng fork—but it's far

amiliar transparent, is a remarkable s piezoelectric char- voltage is applied quartz, it bends slight- z in an oscillator cir- vibrate at its natural is determined by its

oscillation frequency t quartz watches are n seconds per month. ch makers guarantee hin five seconds a ex people conserva- curacy of 15 seconds

Micro-electronic integrated circuits come in here. "Dividers" in these circuits "step down" the frequency by halving it several times (8,192 frequency is the 13th power of 2— 2^{13}). The number of dividers in the circuit depends on the quartz-crystal frequency and other circuitry a particular company uses.

Whether the pulse is divided down to one pulse or a slightly higher frequency (256 in the Swiss movements), an electro-mechanical motor receives the pulse and converts electrical energy to mechanical energy. This drives the wheel train that eventually turns the hands. Of course, each company's watch works a little differently. (See explanations above.)

First, the big mystery is why the Timex is so much cheaper—between a third and a quarter of the price of its nearest competitor. Undoubtedly, there are at least two reasons.

First, a technology geared to enormous production. "We have developed mass-production techniques unmatched outside the United States," says Joakim Lehmkuhl, president of Timex. "You can't produce 19 million

watches a year, as we've been doing without learning a great deal about automated mass production and methods of cost control. When it came to actually manufacturing the quartz watch we already had a backlog of experience in essential fields like the design and manufacture of parts, especially miniaturized parts."

Timex produces all the parts in its watches—except the quartz-crystal oscillator and the circuit. At Waterbury, Conn., I watched skilled workers assemble the watches.

My guide, an engineer, pointed out that in the field of conventional watches, Timex has been manufacturing pin-lever movements, which are less expensive to produce than the Swiss and Japanese jeweled movements. But he, like the others I talked to at Timex, would not agree that their quartz-crystal watch used a basically less-advanced mechanism than its competition. This leads directly to the second reason for lower cost.

Despite the lack of any available proof, Timex has apparently figured out some way to simplify the design and reduce the cost of building a quartz-crystal watch with a super

mass-production technology and a circuit that's still top secret

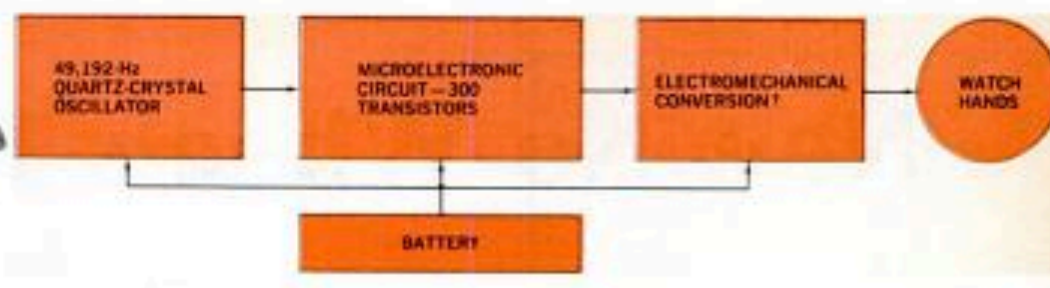

TIMEX What's inside? We don't know yet. At press time the technical information was still "top secret." We do know that the Timex movement uses a crystal oscillator with a 49,192-Hz frequency—far higher than any other quartz on the market. This frequency is not a power of two as in the others—which makes it even

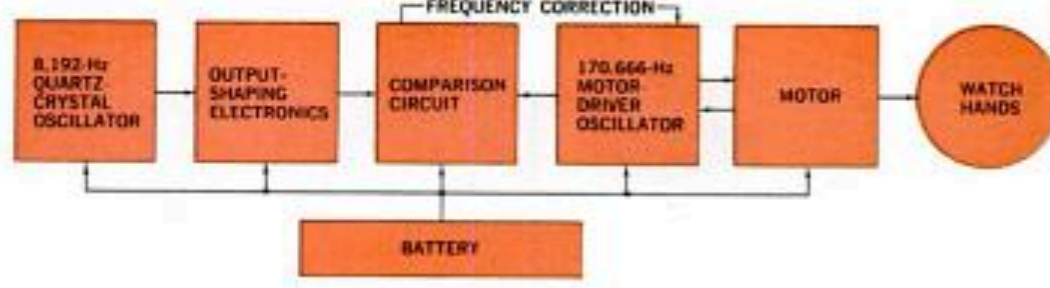
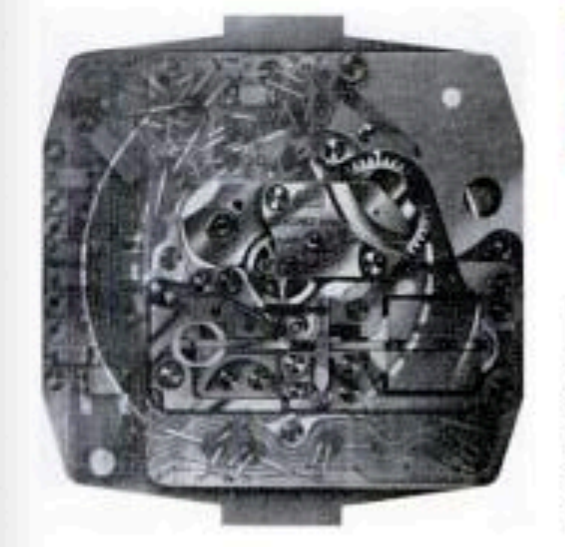

LONGINES This one's unique: A comparison circuit detects error in the watch's output and self-corrects. A 9,350-Hz quartz oscillator is the frequency reference—which is not divided, as in other watches. A 170-Hz servomotor, independent and operating by itself, turns the hands. Mechanical output is compared

high frequency. The company has apparently made an important breakthrough in quartz-watch technology—one that gives it a tremendous advantage—and company engineers and executives are understandably reluctant to reveal their secret.

Although the Timex people showed me various versions of their watch, they refused permission to photograph it—face or movement. Nevertheless, Timex executive vice-president Robert Mohr did give POPULAR SCIENCE some exclusive technical information, emphasizing that "our watch, as far as I know, is entirely different from any other quartz watch." This, along with our speculation of what's inside it, is above.

How about watch performance? Reliability? "Since there are virtually no moving parts," says Lehmkuhl, "very little can go wrong. We have put the watch through every conceivable test of temperature, altitude, and humidity. We have made every test for position error—dial up, dial down, three o'clock up, six o'clock up, nine o'clock up. Where we found bugs we corrected them."

And shock and water resistance?

"Water resistant, yes. As for being shock resistant..." Lehmkuhl smiled. "It is sturdy, but we don't recommend that you hurl it against walls as we did in torture tests with our conventional watches. We wouldn't recommend such treatment for any item that costs over \$100."

In any event, Timex seems destined to be the first to market the new watch in quantity, and Seiko threatens to be a close second. Why aren't the Swiss (such as Bulova, Omega, Longines, and others) marketing quartz watches in large numbers?

Tuning-fork watches. Bulova has had a lot of success with its Accutron tuning-fork watch. Now other Swiss companies have been licensed by Bulova to make tuning-fork watches. As one Swiss manufacturer said, "We want to make the most of our tuning-fork watch, which represents a heavy investment. Time enough for the quartz watch when the tuning-fork has passed the peak of popularity."

Another predicted differently. "Timex and its advertising campaign for the quartz watch may well be the catalyst that will compel all of us to jump in and compete."

I asked Joakim Lehmkuhl of Timex how far away he thought the era of the quartz watch might be.

"We don't expect a hundred million Americans to throw away their watches tomorrow morning in order to buy a quartz watch. We are dealing not only with watches, but with human nature. We expect, as new watches are bought, that purchasers will want the latest and most accurate type. Simply because the quartz watch is unquestionably the newest and most accurate example of horology man has so far achieved, we are confident that it will be, if not the dominant watch of tomorrow, surely that of the day after tomorrow."

And what can we expect, the day after that? Nuclear timekeeping. Some day you may be able to buy a watch containing a milligram of an alpha-particle-emitting radioactive isotope as a power source. It may be accurate to within a few seconds a year—almost as accurate as the movement of the Earth itself! Although Bulova's engineers are already exploring nuclear timekeeping, they believe it's a long way off. Name? What else but the atomic watch? □

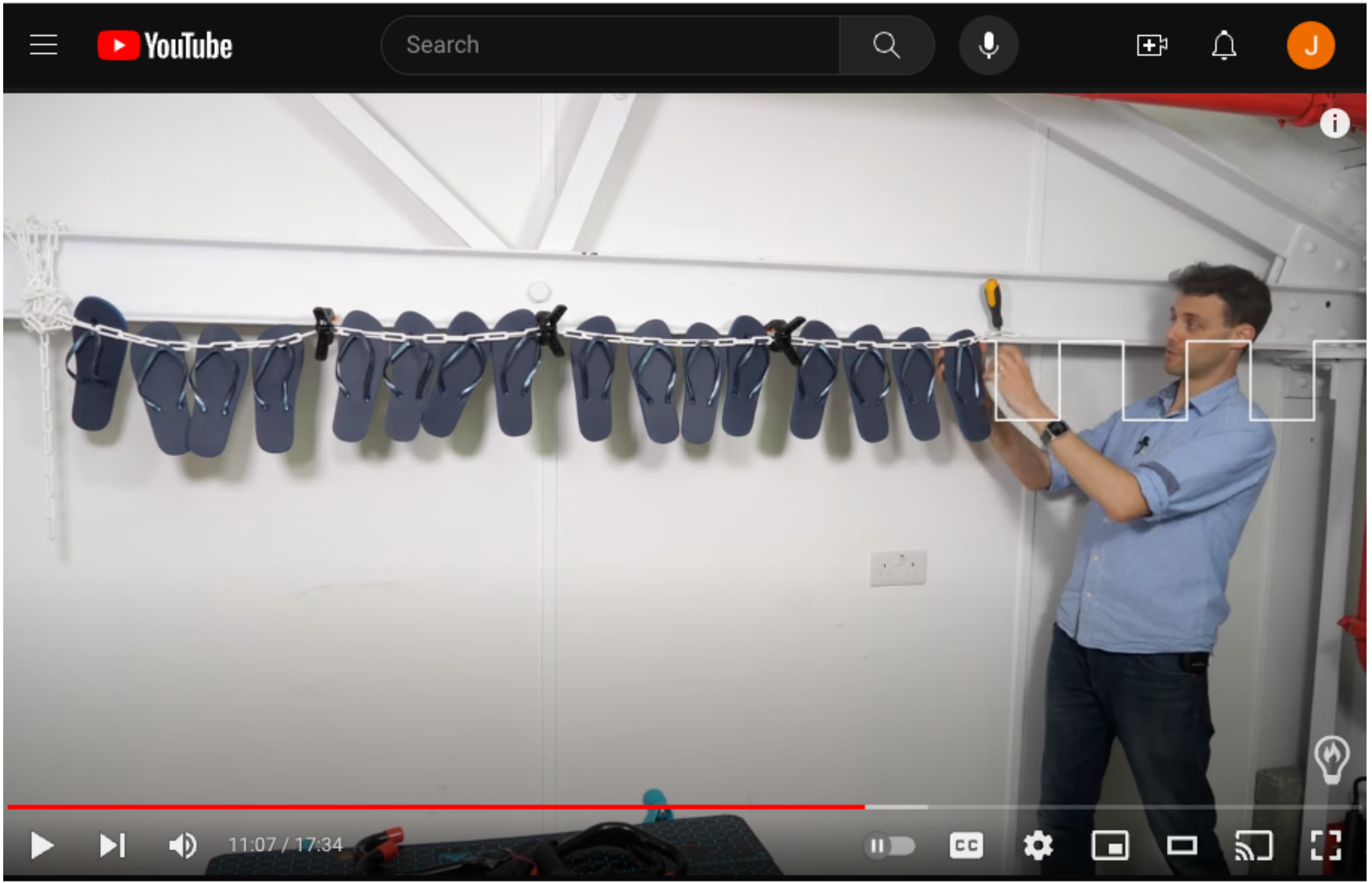

How a quartz watch works - its heart beats 32,768 times a second

 **Steve Mould** ✓
2.76M subscribers [Subscribe](#)

 188K |  |  Share |  Download | 

6.9M views 4 years ago
Get 75% off NordVPN with this link: <https://nordvpn.com/steve> and use the promo code steve to get the first 30 days free.
Quartz watches have a tiny crystal tuning fork inside that vibrates at 2^{15} Hz and there's a really clever reason for that. This video ...more

https://www.youtube.com/watch?v=_2By2ane2l4&t=351s

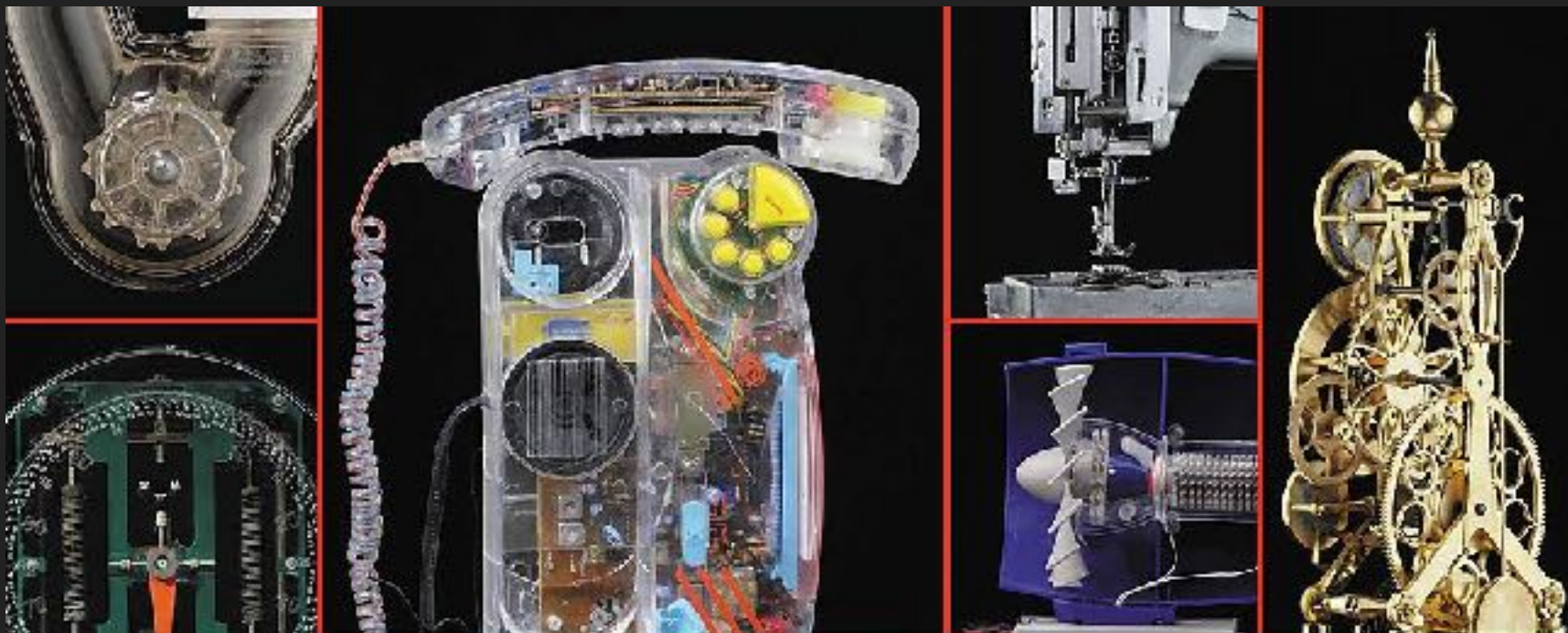

HOW THINGS WORK

THE INNER LIFE OF EVERYDAY MACHINES



THEODORE GRAY
 bestselling author of *The Elements*
 Photographs by Nick Mann

Pendulum Clocks

THE FIRST REALLY GOOD mechanical clocks were tick-tock style pendulum clocks. The invention of the pendulum as a way of telling time was a huge advance in accuracy. Overnight, clocks went from drifting off by 15 minutes or more every day, to the best staying within 10 seconds per day.

This Chinese copy of an old French design shows off the very definition of "clockwork." Gears upon gears, folded in on each other, all moving together in ways that are, well, pretty confusing. To help make things understandable, I've made a spread-out model for you.



86 HOWTHINGS WORK

FOR THE BENEFIT of those of you born in the present millennium, a primer on clocks of the old school. This is the universal symbol of time, the clock face. There are three "hands," which all turn around the same central point. Around the outside there are two sets of marks: one set of 60 small tick marks for seconds and minutes, and one set of 12 large tick marks for hours. This clock is showing 10:14:35 (14 minutes and 35 seconds after 10 o'clock).

The three hands on a clock are all turning around the same point, but they are turning at wildly different speeds. It takes 60 times longer for the minute hand to go around than the second hand, and the hour hand is another 12 times slower. For every complete turn of the hour hand, the second hand has to go around 720 times. This huge difference in speed is created by a mess of gears on the back of the clock.

The "hour hand" moves forward one large tick mark per hour, and takes 12 hours to go around one full turn. This hour hand is pointing about one-quarter of the way from the 10 mark to the 11 mark. That's because we are 14 minutes (and 35 seconds) past 10 o'clock.

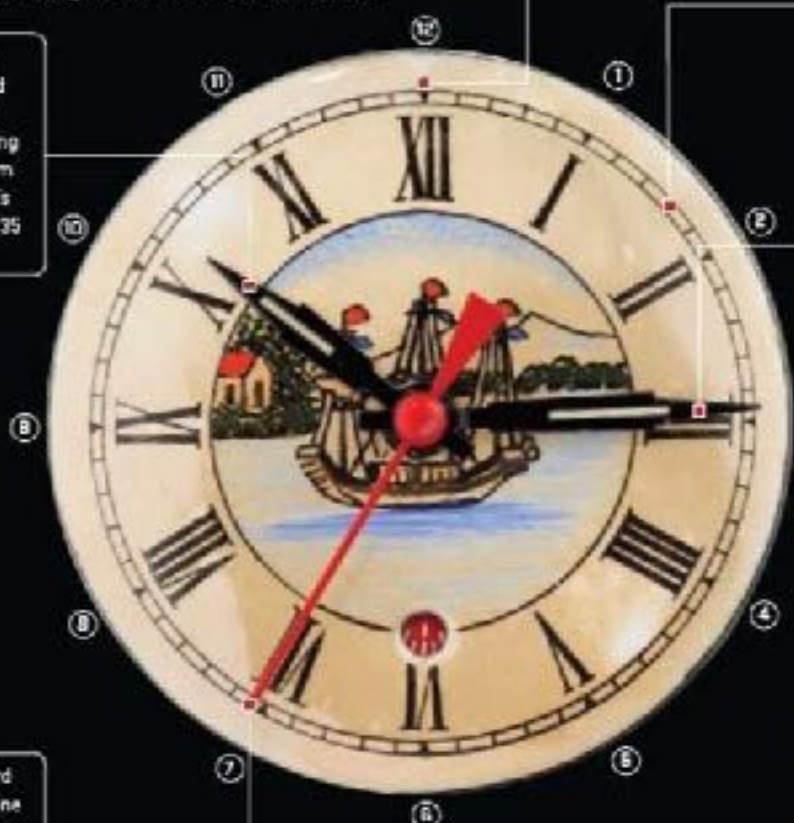

The large tick marks with numbers (Roman numerals in this case) mark the hours.

The small tick marks, often not numbered, mark the minutes and seconds. You're just supposed to know that each hour mark corresponds to an interval of 5 minutes (for the minute hand) or 5 seconds (for the second hand). Each quarter of the circle is 15 minutes or 15 seconds, respectively.

The "minute hand" moves forward one small tick mark each minute, and takes one hour (60 minutes) to go around one full turn. This minute hand is pointing a little over halfway from the 14 minute mark to the 15 minute mark. That's because we are 35 seconds—about halfway—between those two minutes.



There is something amusing in the fact that the telephone app on today's iPhones has an icon that looks like a phone no one has used in twenty years, and the clock app looks like a clock most people rarely see anymore. (It's also amusing that a separate telephone app is necessary on a device that is, by name, already a phone. But the truth is, making phone calls is one of the iPhone's least commonly used functions.)

The "second hand" moves forward (in the "clockwise" direction) by one small tick mark each second, and takes one minute (60 seconds) to go around one full turn. This second hand is pointing at the 35 second mark.

CLOCKS 87

“We’ve now arrived at the subject of really accurate time. Earlier I said that up until 1955 a glorified sundial was the most accurate clock in existence. Another way of saying this is that we were using the rotation of the earth as the reference standard for time, because we didn’t have anything better.

Every day the time told by the world’s best clocks was compared to the exact moment that a set of reference stars past directly overhead at the Greenwich Observatory in London. If there was a deviation between when the clocks said the stars should pass overhead and when they actually did, we trusted the stars over the clocks, and reset the clocks. Based on everything we knew about the earth and the clocks there was no reason to think that the clocks were a more accurate measure of time to the rotation of the earth.

Two clocks, even if one is the earth, are not enough. But if you have three clocks, and you find that two of them stay exactly in sync with the third one drifts away, now you’ve got some evidence that the third one is the problem. If you have 100 clocks spread all over the world, built by different people using different methods, and all but one of them agree with each other, then you can be pretty sure that the outlier is the problem, not the other 99 clocks. In 1955 the earth became that outlier — not because of anything changed about the earth but because we suddenly got much better at building clocks. What changed in 1955 with the invention of the cesium atomic clock.”

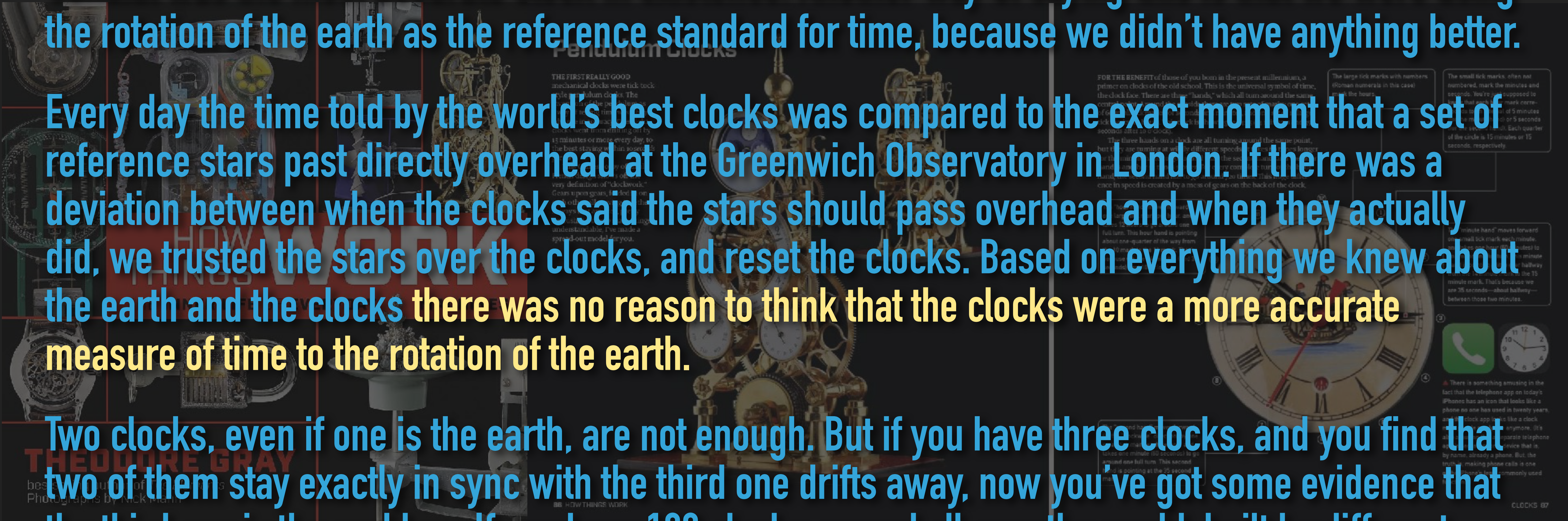

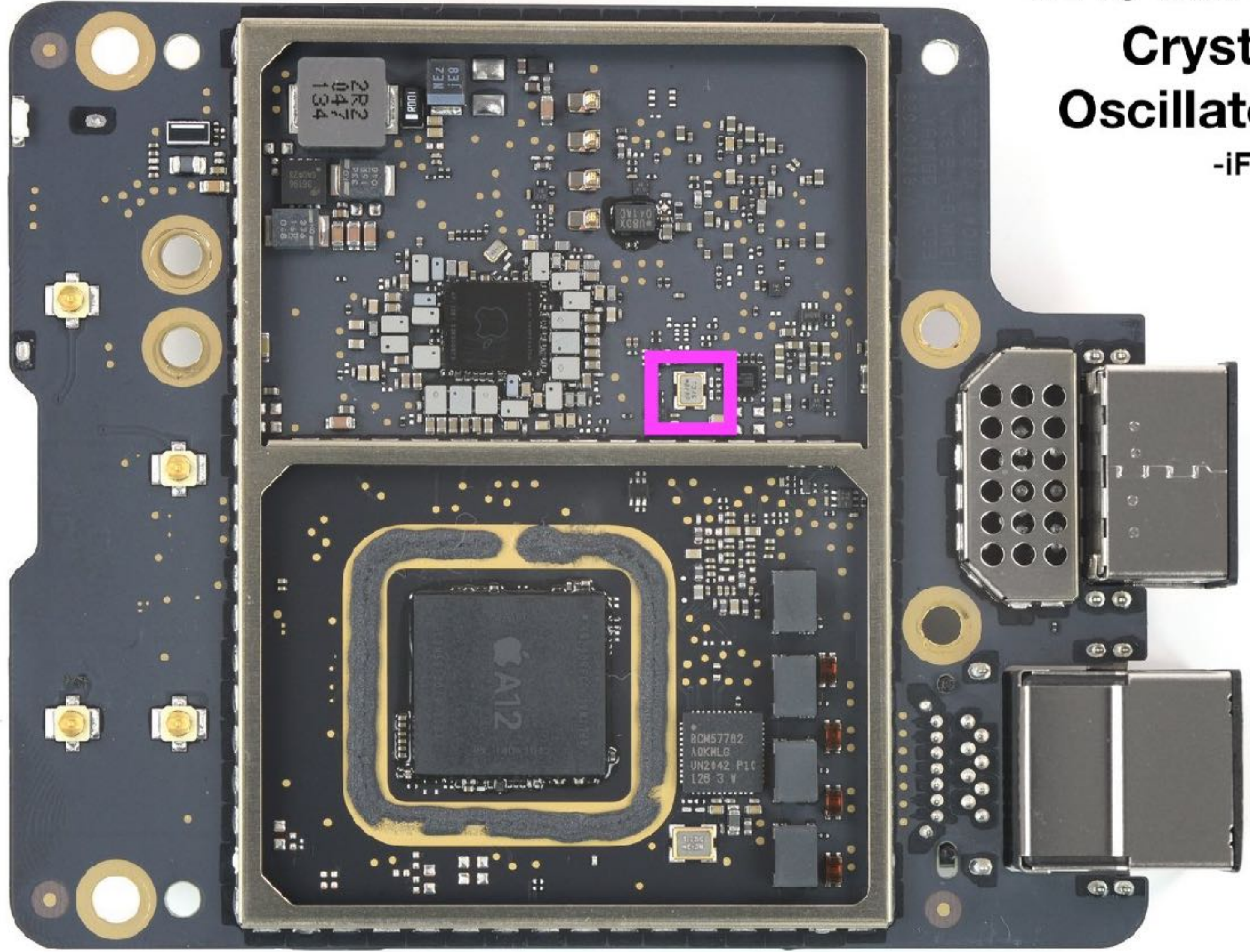

**T245 MrHP
Crystal
Oscillator**
-iFixIt

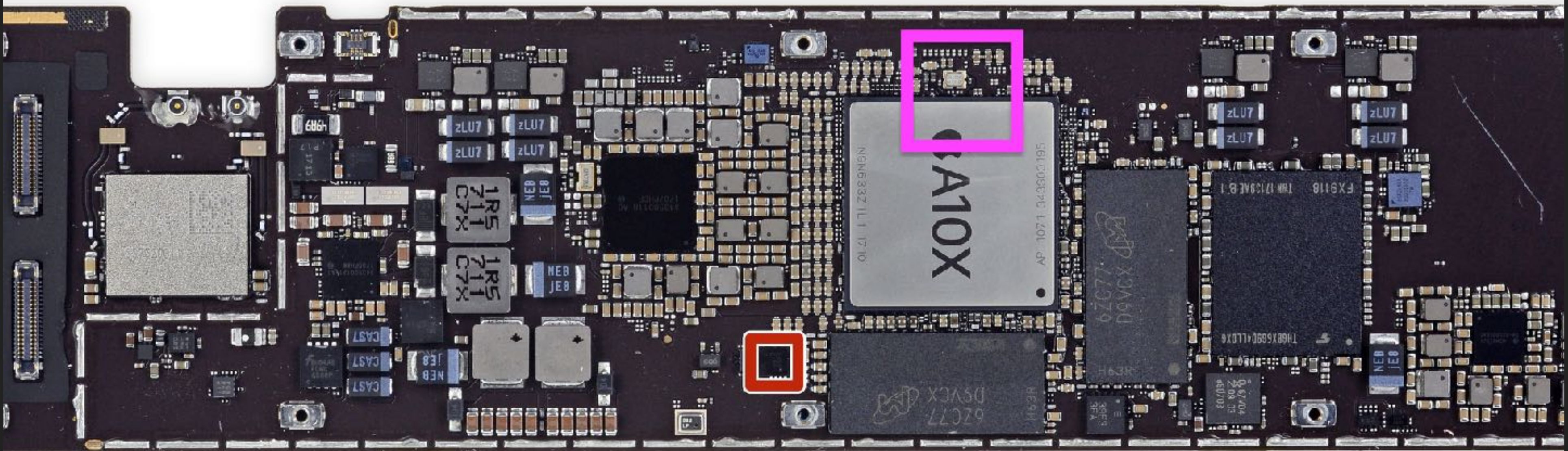

**Xiomi Watch
26Mhz Oscillator
(probably)
iFixIt**

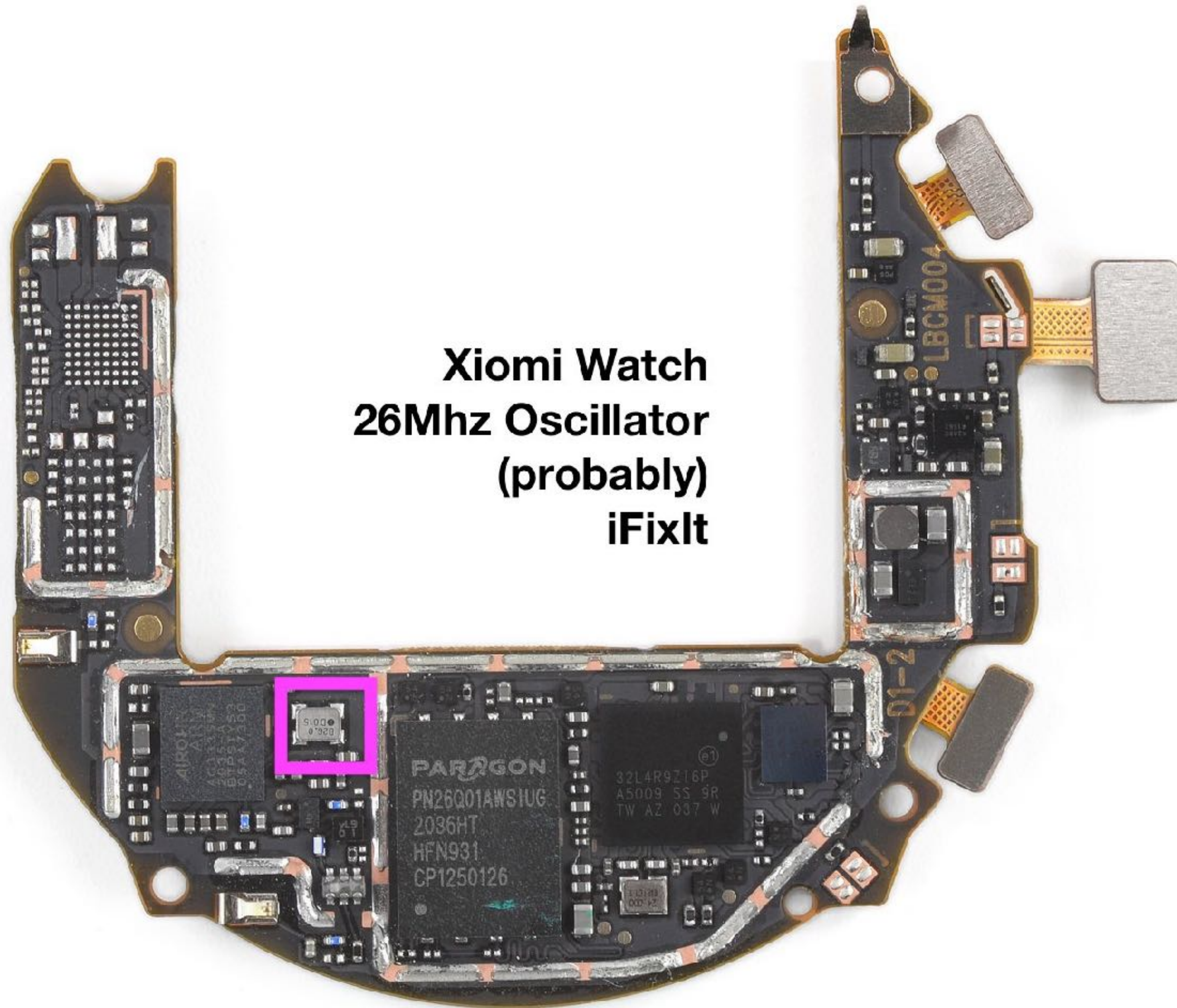

NBVSBAXXX Series

2.5 V/3.3 V, LVPECL Voltage-Controlled Crystal Oscillator (VCXO) PureEdge™ Product Series

The NBVSBAXXX series voltage-controlled crystal oscillator (VCXO) devices are designed to meet today's requirements for 2.5 V and 3.3 V LVPECL clock generation applications. These devices use a high Q fundamental mode crystal and Phase Locked Loop (PLL) multiplier to provide a wide range of frequencies from 60 MHz to 700 MHz (factory configurable per user specifications) with a pullable range of ± 100 ppm and a frequency stability of ± 50 ppm. The silicon-based PureEdge™ products design provides users with exceptional frequency stability and reliability. They produce an ultra low jitter and phase noise LVPECL differential output.

The NBVSBAXXX series are members of ON Semiconductor's PureEdge™ clock family that provides accurate and precision clock generation solutions.

Available in the industry standard 5.0 x 7.0 x 1.8 mm and in a new 3.2 x 5.0 x 1.2 mm SMD (CLCC) package on 16 mm tape and reel in quantities of 1,000.

Features

- LVPECL Differential Output
- Operating Range: 2.5 V $\pm 5\%$, 3.3 V $\pm 10\%$



ON Semiconductor®

<http://onsemi.com>

MARKING DIAGRAM

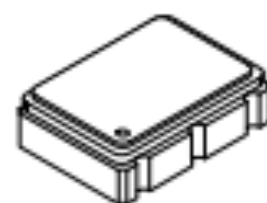

6 PIN CLCC
LN SUFFIX
CASE 848AB

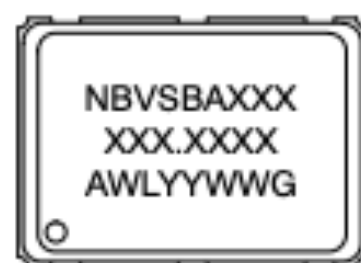

6 PIN CLCC
LU SUFFIX
CASE 848AC

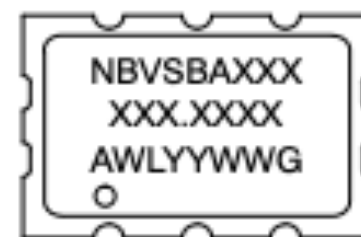

NBVSBAXXX = NBVSBAXXX (± 50 ppm)
XXX.XXXX = Output Frequency (MHz)
A = Assembly Location

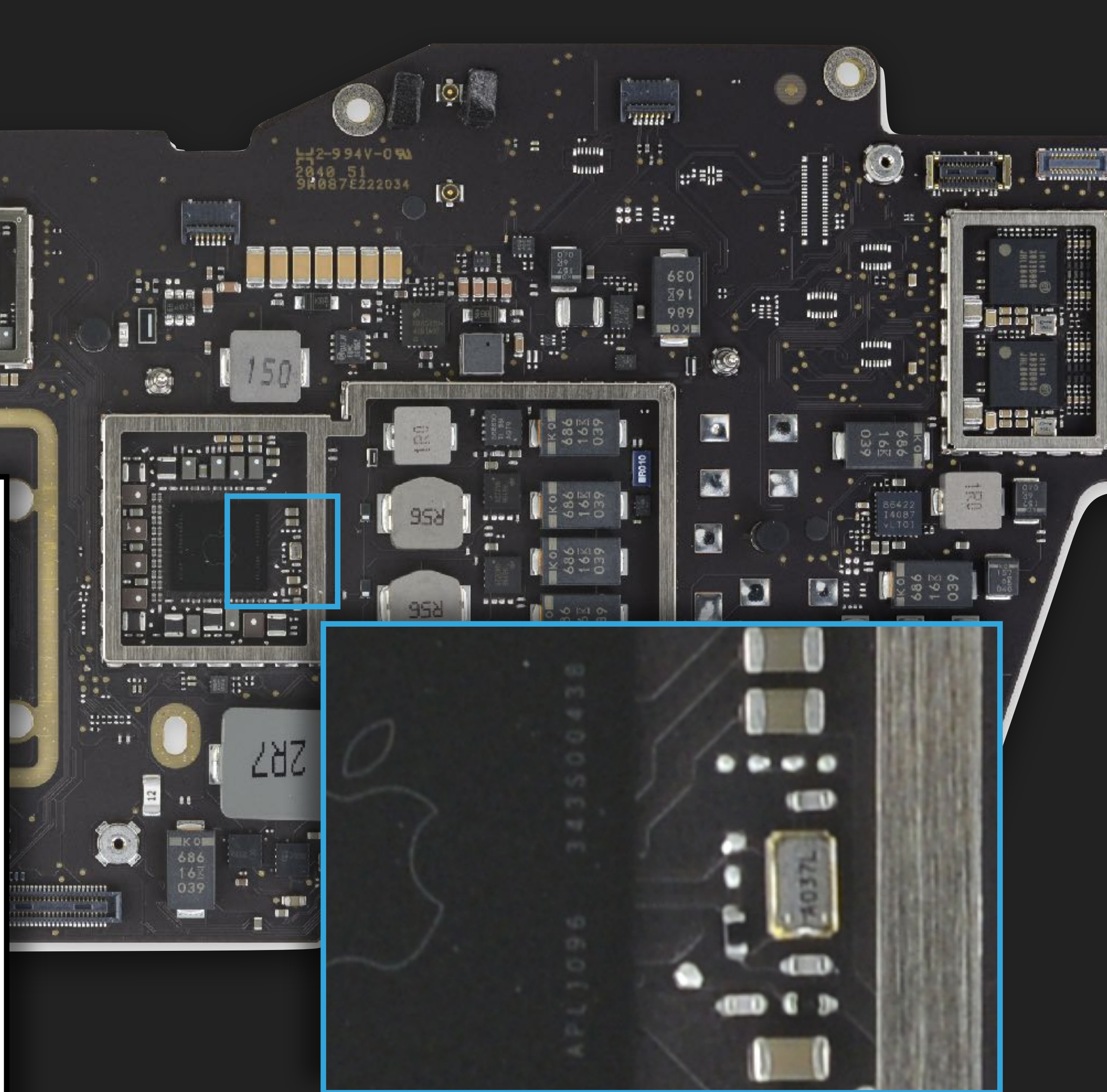

ONSEMI A037L 707.35MHz VCXO

Clock Trees



GAN-CTS optimized
(clk WL: 42.36 mm)

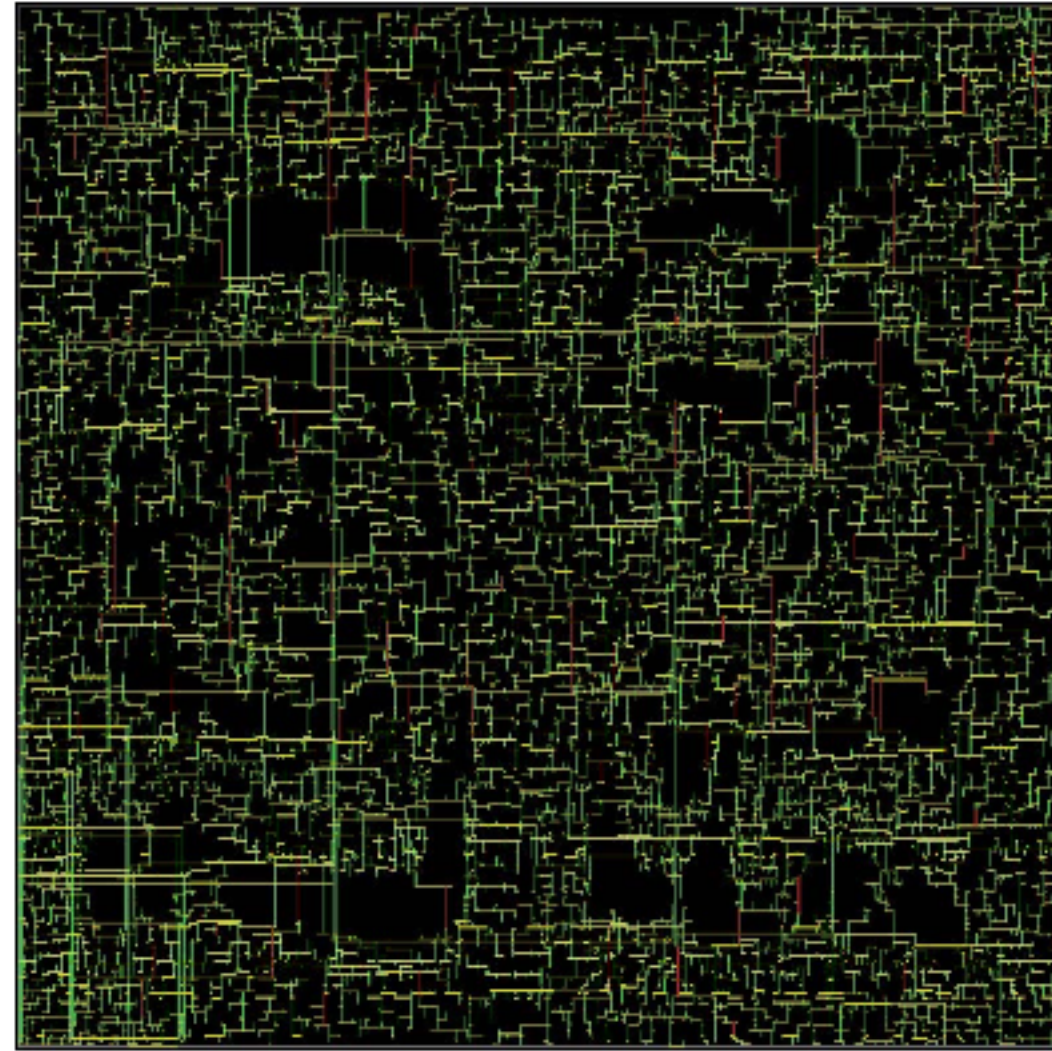

commercial auto-setting
(clk WL: 49.69mm)

Design: ECG

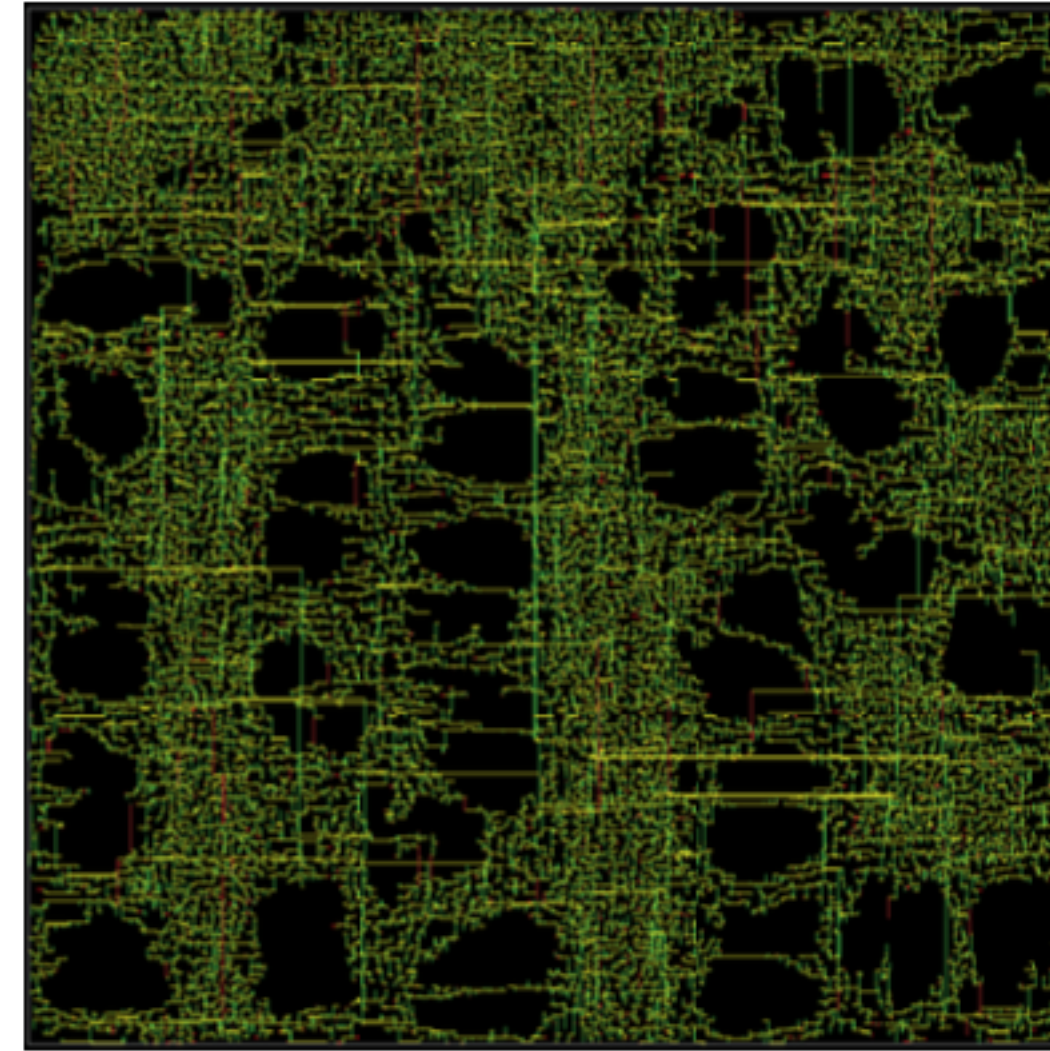

GAN-CTS optimized
(clk WL: 115.22mm)

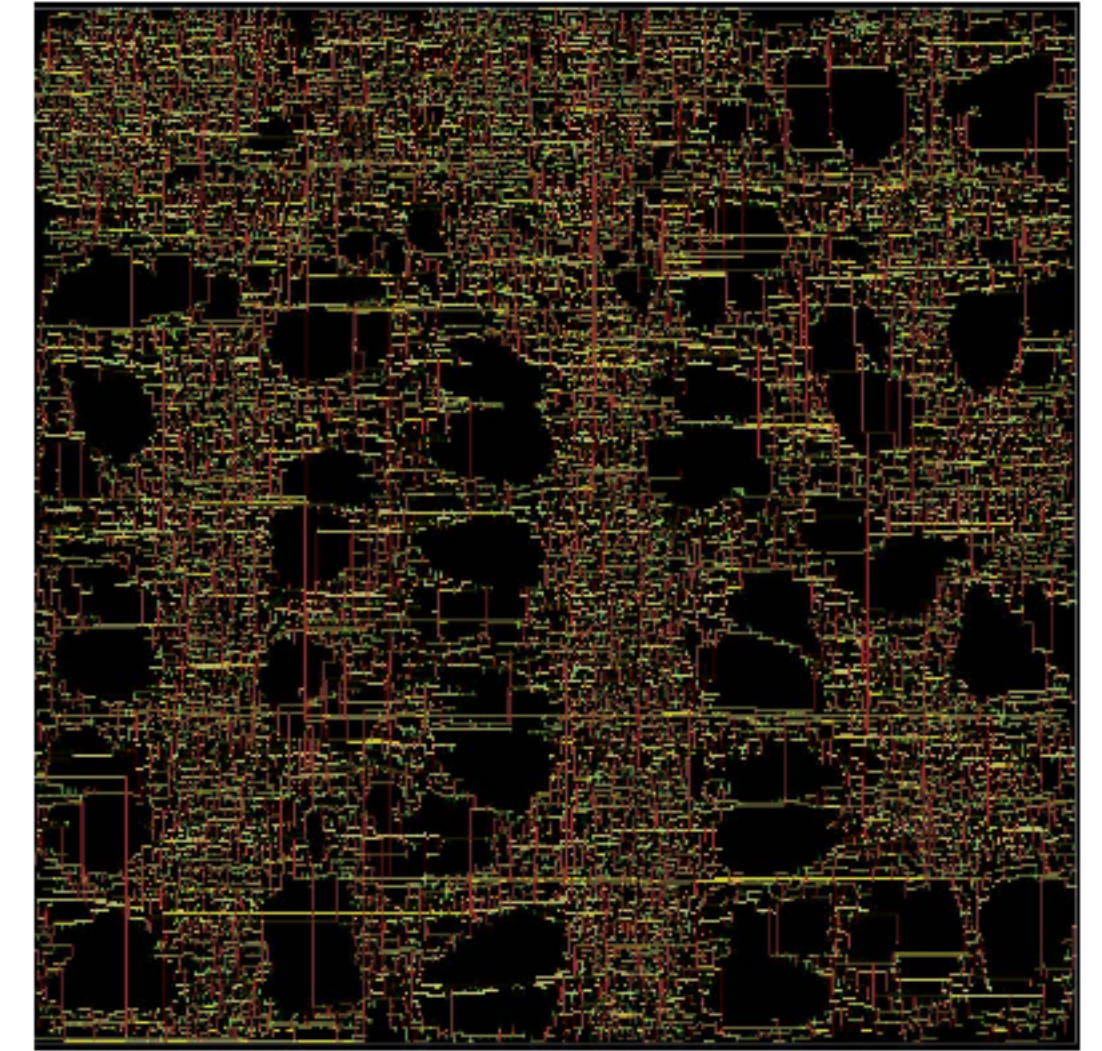

commercial auto-setting
(clk WL: 130.71mm)

Design: JPEG

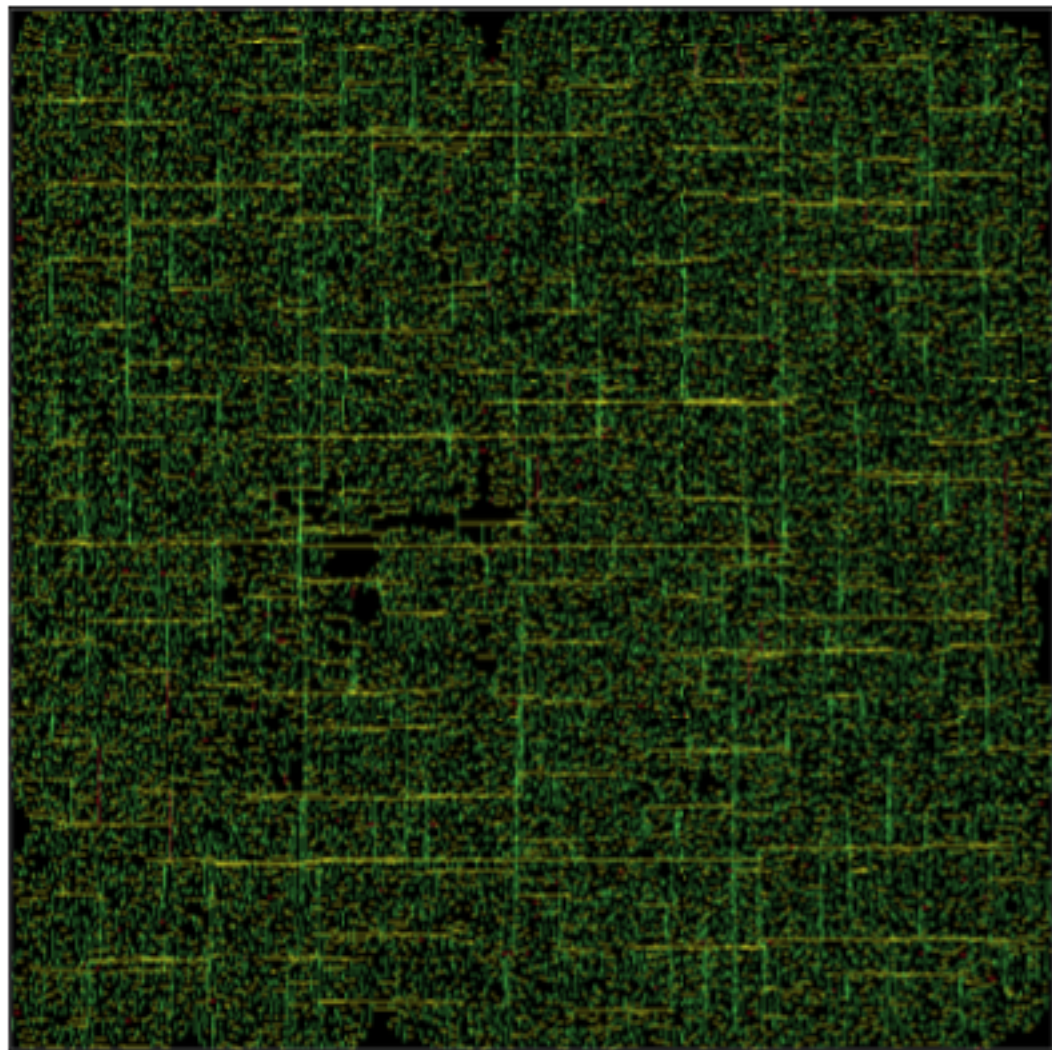

GAN-CTS optimized
(clk WL: 296.15mm)

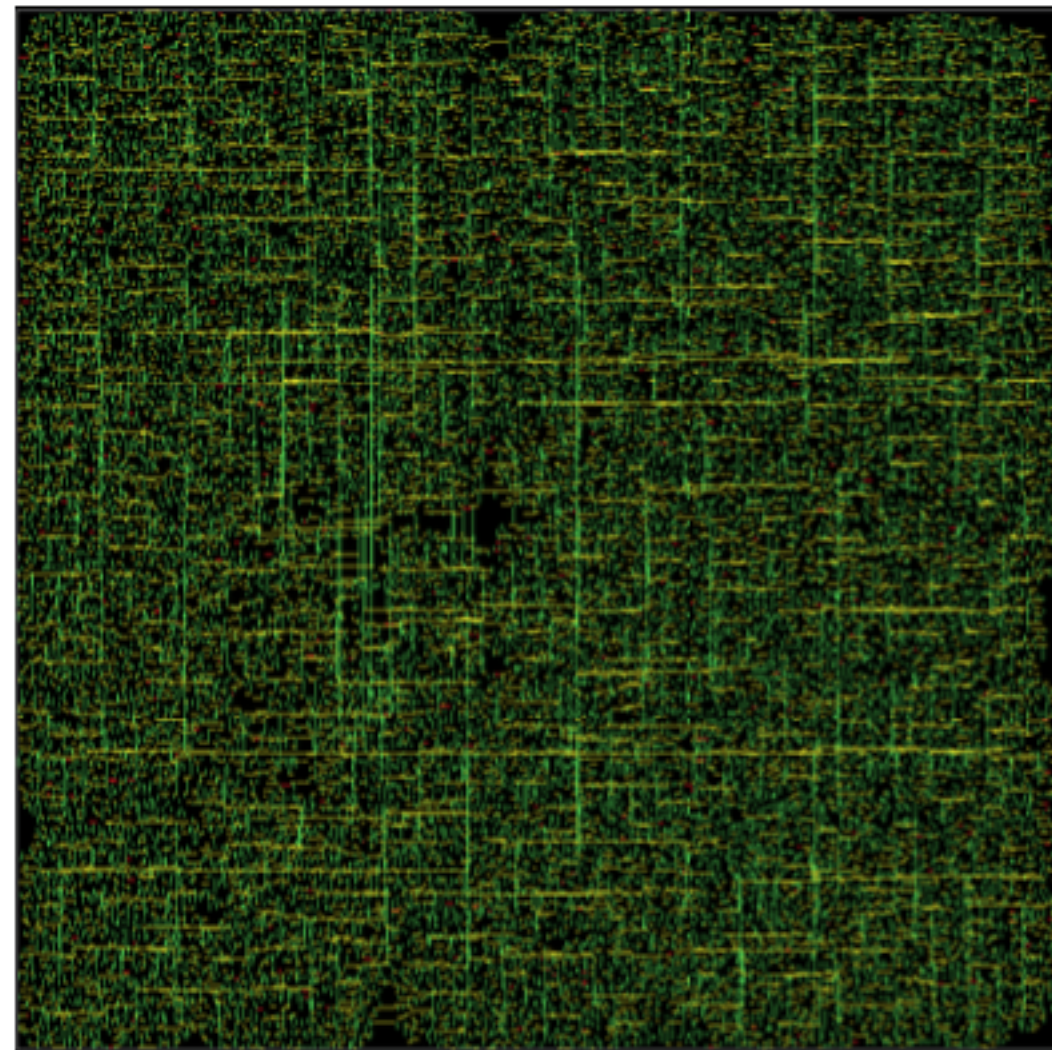

commercial auto-setting
(clk WL: 326.36mm)

Design: LEON3MP

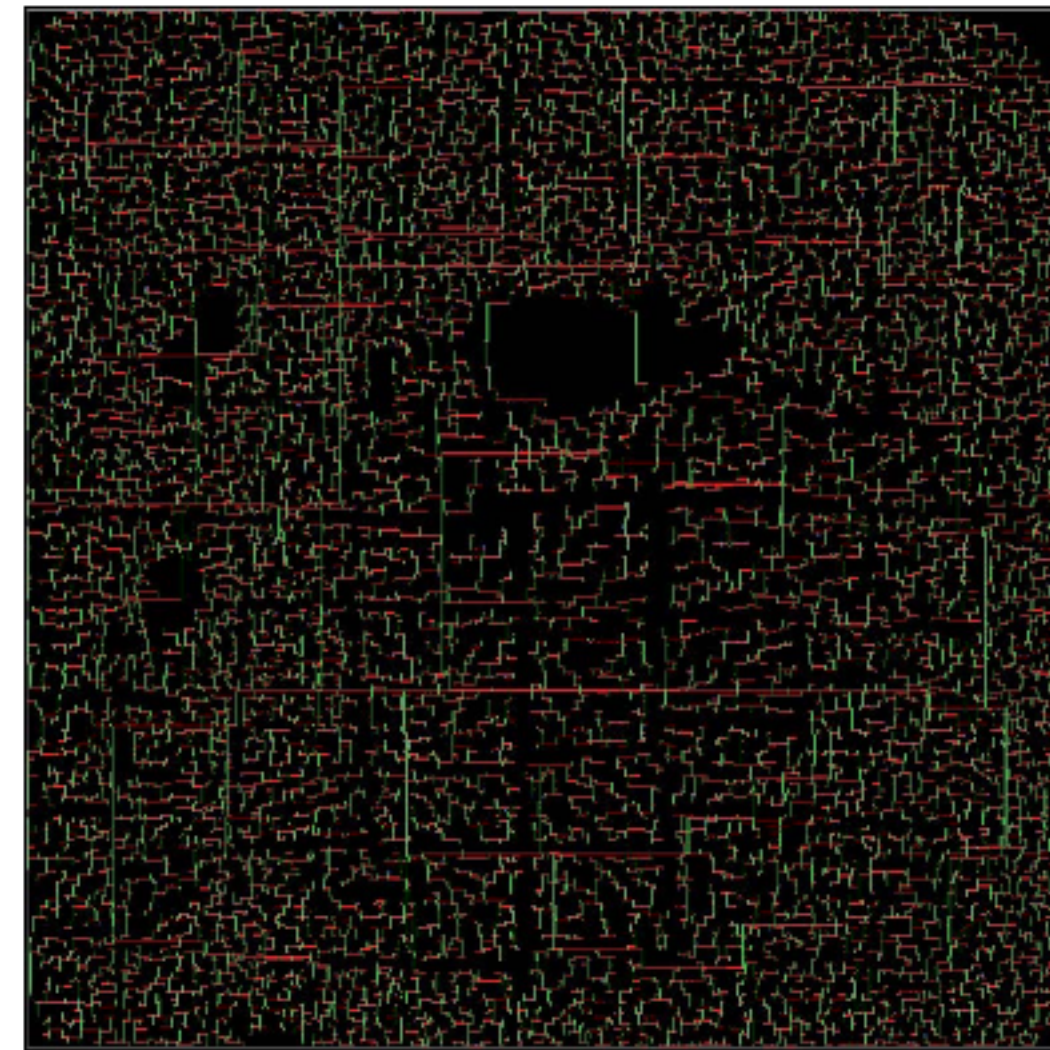

GAN-CTS optimized
(clk WL: 41.29mm)

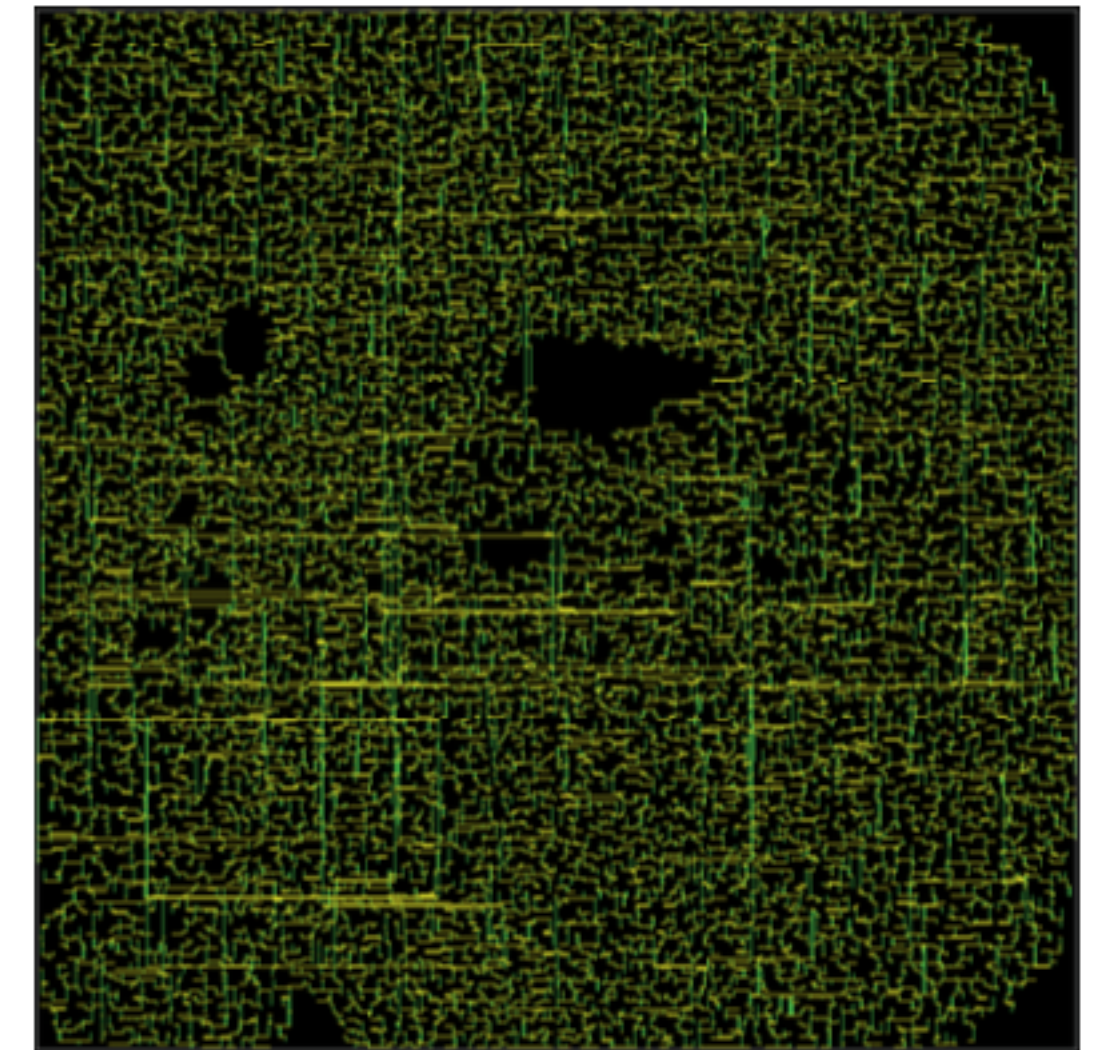

commercial auto-setting
(clk WL: 52.61mm)

Design: VGA_LCD

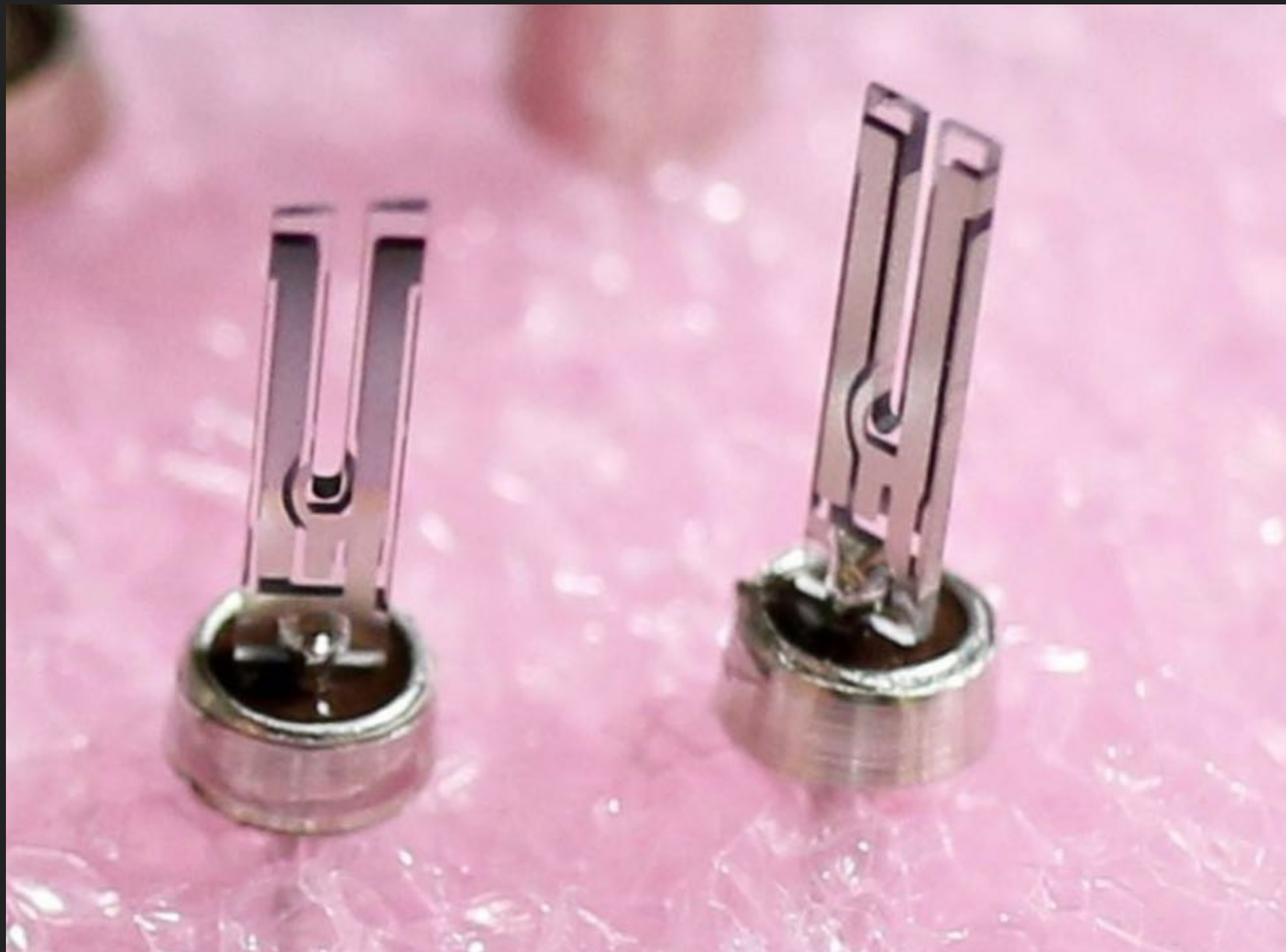

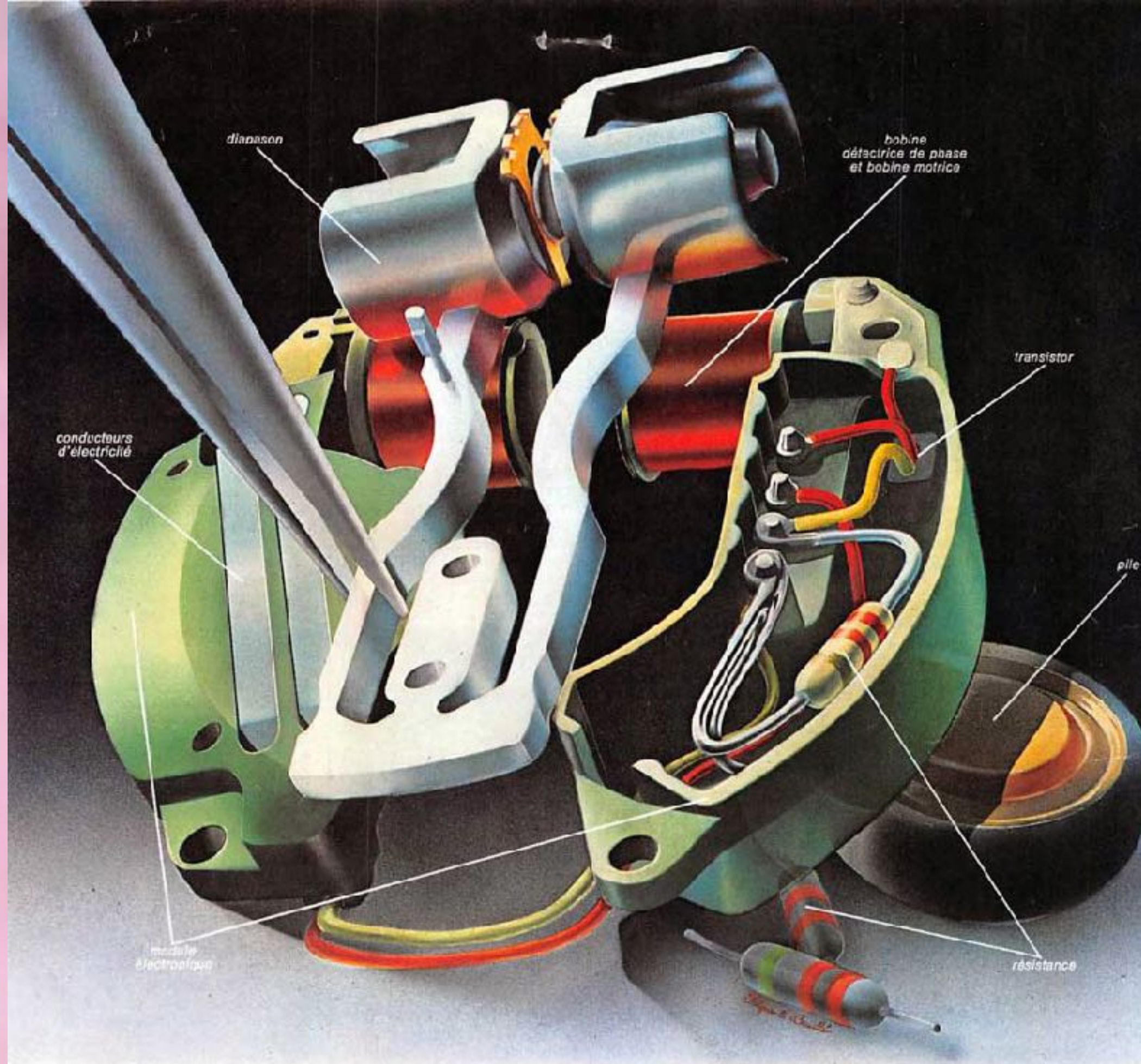

Bulova Accutron, première montre électronique à diapason.

L'électricité lui donne son énergie, l'électronique sa haute précision.

Dans une Bulova Accutron, l'énergie d'une pile est transmise à un diapason au moyen d'un circuit électronique intégré. Parce que l'énergie électrique n'a jamais été un facteur déterminant de précision, ce circuit électronique détecte et maintient à un degré constant la fréquence des oscillations du diapason (au moins 360 par seconde); ce qui permet d'obtenir au porter une



précision de 99,9977 % garantie par écrit. On est loin de l'à-peu-près d'un mécanisme traditionnel à balancier! Les deux montres ci-contre font partie des 100 modèles de la collection Bulova Accutron pour hommes et dames que vous trouverez chez tous les bijoutiers horlogers concessionnaires de la marque Bulova (à partir de 595 F)

BULOVA ACCUTRON
A chaque seconde, une certitude.

PUBLICIS H 2004 © marque déposée

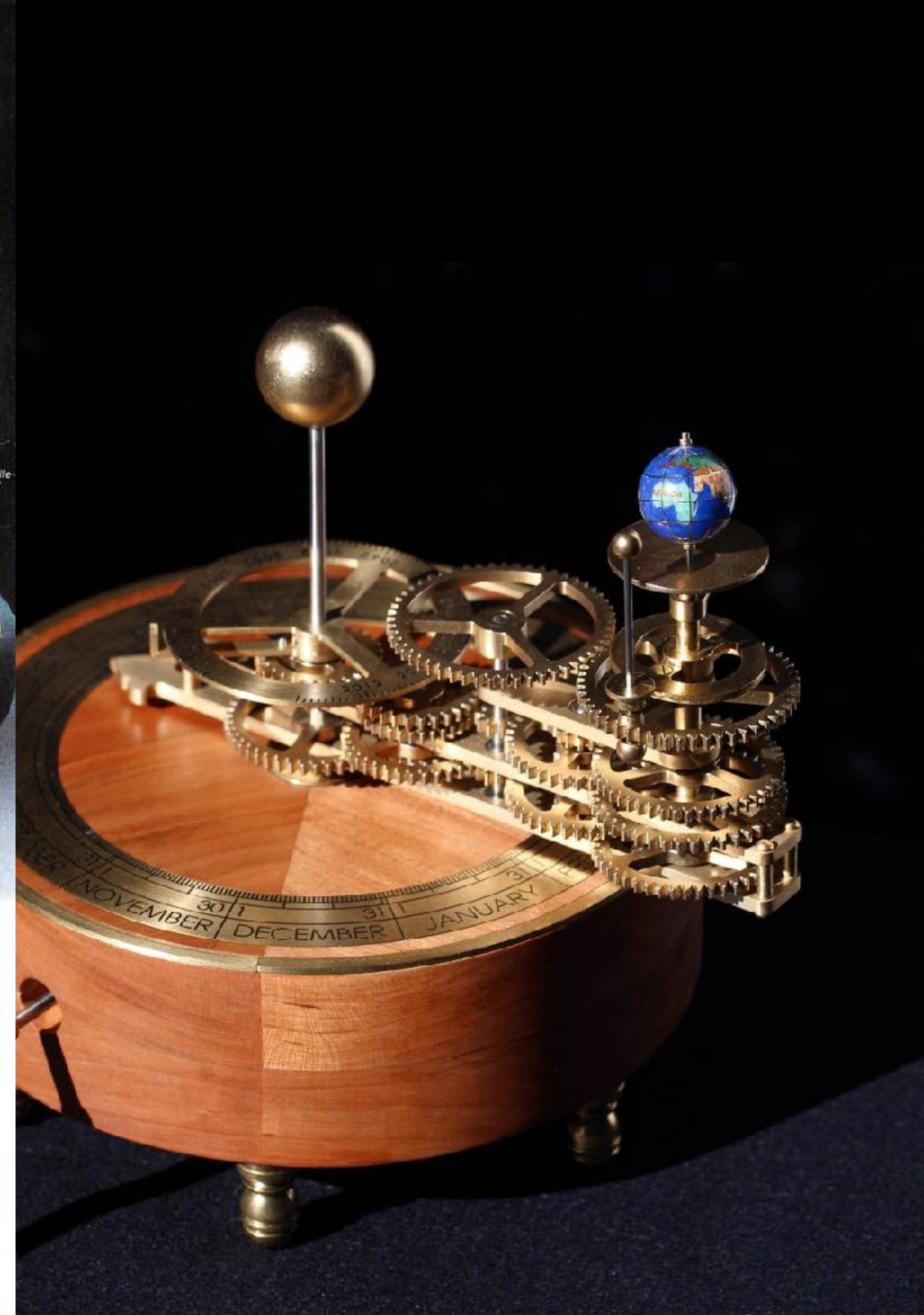

Standard quartz clock timer
 $32,768 = 2^{15}$

The screenshot shows the Mouser Electronics website with the following details:

- Page Title: quartz crystal Crystals | Mouse
- URL: mouser.com/Passive-Components/Frequency-Control-Timing-Devices/Crystals/_/...
- Breadcrumbs: All Products > Passive Components > Frequency Control & Timing Devices > Crystals
- Share button: Share
- Link: Show other information about "quartz crystal" See related content >>
- Section: quartz crystal Crystals
- Filters: Products (14,631), Datasheets (5,387), Images (159), Newest Products
- Results: 14,631 | Smart Filtering
- Applied Filters: Passive Components, Frequency Control & Timing Devices, Crystals
- Filter Categories: Manufacturer, Termination Style, Package / Case, Load Capacitance, Frequency, Tolerance
- Frequency Filter: 32.768 kHz (circled in blue)
- Buttons: Reset All, Apply Filters

Manufacturer	Termination Style	Package / Case	Load Capacitance	Frequency	Tolerance
--- Most Popular --- ABRACON ECS Epson TXC Corporation CTS Kyocera NDK Citizen	Radial SMD/SMT	1.2 mm x 1 mm 1.6 mm x 1 mm 1.6 mm x 1.2 mm 10.41 mm x 4.06 mm 11 mm x 5 mm 11.35 mm x 4.65 mm x 3.5 mm 11.4 mm x 4.9 mm 11.7 mm x 4 mm 11.7 mm x 4.8 mm 11.8 mm x 5.5 mm 12.4 mm x 4.7 mm 12.5 mm x 4.6 mm 13.1 mm x 5 mm 13.2 mm x 4.8 mm 13.3 mm x 4.85 mm 2 mm x 1.2 mm	4 pF 5 pF 6 pF 7 pF 7 pF to 32 pF 8 pF 8.5 pF 9 pF 10 pF 11 pF 12 pF 12.5 pF 13 pF 14 pF	20 kHz 25.6 kHz 31.25 kHz 32 kHz 32.768 kHz 38.4 kHz 60 kHz 76.8 kHz 96 kHz 100 kHz 1 MHz 1.84 MHz 1.8432 MHz	10 PPM 15 PM 15 PPM 20 PPM 25 PPM 30 PPM 50 PPM 100 PPM -



Precision timer
 $2,097,152 = 2^{21}$



```
Encoder: 211
Encoder: 212
Encoder: 213
Encoder: 212
Encoder: 213
Encoder: 214
Encoder: 215
Encoder: 216
Encoder: 217
Encoder: 218
Encoder: 219
Encoder: 220
Encoder: 221
Encoder: 222
Encoder: 223
Encoder: 224
```

$$1,843,200 / 16 = 115,200$$
$$/32 = 57,600$$
$$/192 = 9600$$

quartz crystal Crystals

Products (14,631) | Datasheets (5,387) | Images (159) | Newest Products

Results: 14,631 | Smart Filtering

Package / Case	Load Capacitance	Frequency	Tolerance
1.2 mm x 1 mm	4 pF	96 kHz	10 PPM
1.6 mm x 1 mm	5 pF	100 kHz	15 PM
1.6 mm x 1.2 mm	6 pF	15 PPM	20 PPM
10.41 mm x 4.06 mm	7 pF	1.84 MHz	25 PPM
11 mm x 5 mm	7 pF to 32 pF	1.8432 MHz	30 PPM
11.35 mm x 4.65 mm x 3.5 mm	8 pF	2 MHz	50 PPM
11.4 mm x 4.9 mm	8.5 pF	2.048 MHz	100 PPM
11.7 mm x 4 mm	9 pF	2.097 MHz	-
11.7 mm x 4.8 mm	10 pF	2.09715 MHz	-
11.8 mm x 5.5 mm	11 pF	2.097152 MHz	-
12.4 mm x 4.7 mm	12 pF	2.4 MHz	-
12.5 mm x 4.6 mm	12.5 pF	2.4576 MHz	-
13.1 mm x 5 mm	13 pF	2.5 MHz	-
13.2 mm x 4.8 mm	14 pF	-	-
13.3 mm x 4.85 mm	-	-	-
2 mm x 1.2 mm	-	-	-



Sparkfun RTC Breakout boards

https://github.com/ITPNYU/clock-club/tree/master/RTC_Clock_Examples

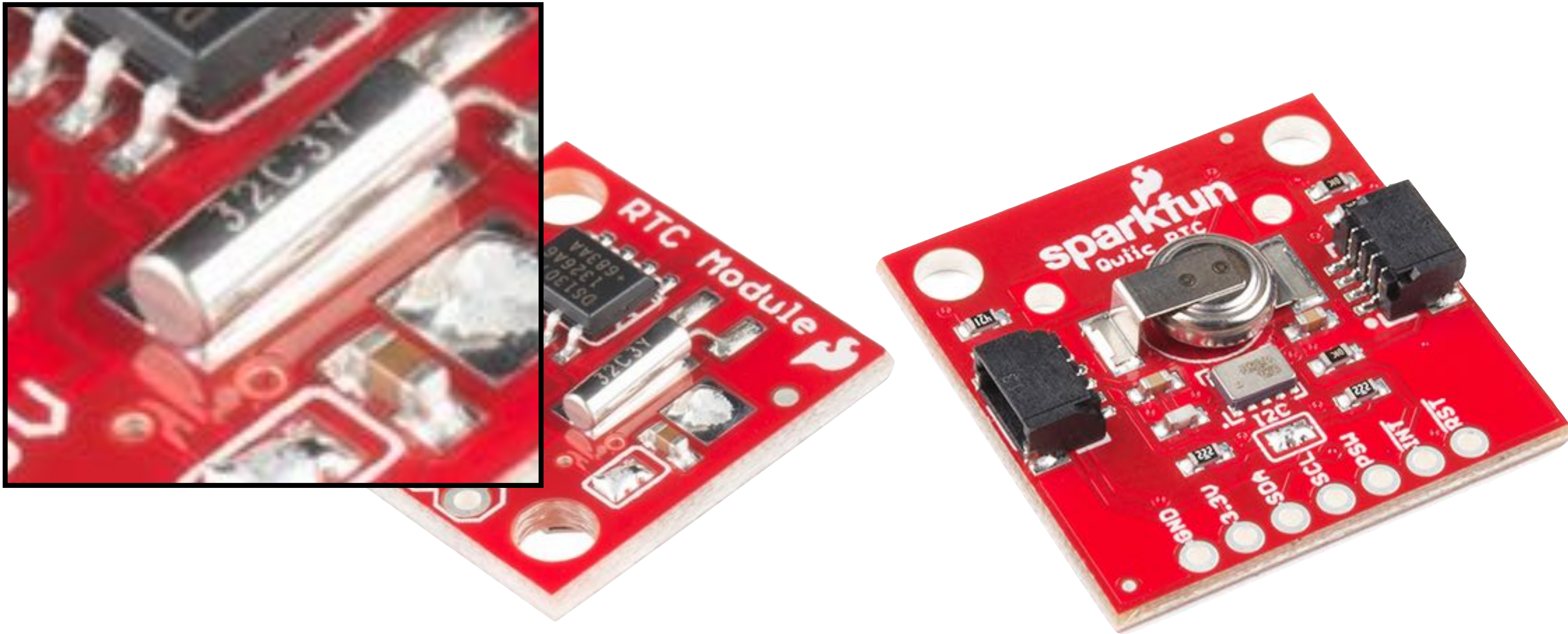

Sparkfun RTC Breakout boards

https://github.com/ITPNYU/clock-club/tree/master/RTC_Clock_Examples

19. RTC – Real-Time Counter

19.1 Overview

The Real-Time Counter (RTC) is a 32-bit counter with a 10-bit programmable prescaler that typically runs continuously to keep track of time. The RTC can wake up the device from sleep modes using the alarm/compare wake up, periodic wake up, or overflow wake up mechanisms

The RTC is typically clocked by the 1.024kHz output from the 32.768kHz High-Accuracy Internal Crystal Oscillator(OSC32K) and this is the configuration optimized for the lowest power consumption. The faster 32.768kHz output can be selected if the RTC needs a resolution higher than 1ms. The RTC can also be clocked from other sources, selectable through the Generic Clock module (GCLK).

The RTC can generate periodic peripheral events from outputs of the prescaler, as well as alarm/compare interrupts and peripheral events, which can trigger at any counter value. Additionally, the timer can trigger an overflow interrupt and peripheral event, and can be reset on the occurrence of an alarm/compare match. This allows periodic interrupts and peripheral events at very long and accurate intervals.

The 10-bit programmable prescaler can scale down the clock source. By this, a wide range of resolutions and time-out periods can be configured. With a 32.768kHz clock source, the minimum counter tick interval is 30.5 μ s, and time-out periods can range up to 36 hours. For a counter tick interval of 1s, the maximum time-out period is more than 136 years.

19.2 Features

- 32-bit counter with 10-bit prescaler
- Multiple clock sources
- 32-bit or 16-bit Counter mode
 - One 32-bit or two 16-bit compare values
- Clock/Calendar mode
 - Time in seconds, minutes and hours (12/24)
 - Date in day of month, month and year
 - Leap year correction
- Digital prescaler correction/tuning for increased accuracy
- Overflow, alarm/compare match and prescaler interrupts and events
 - Optional clear on alarm/compare match



19.3 Block Diagram

Figure 19-1. RTC Block Diagram (Mode 0 — 32-Bit Counter)

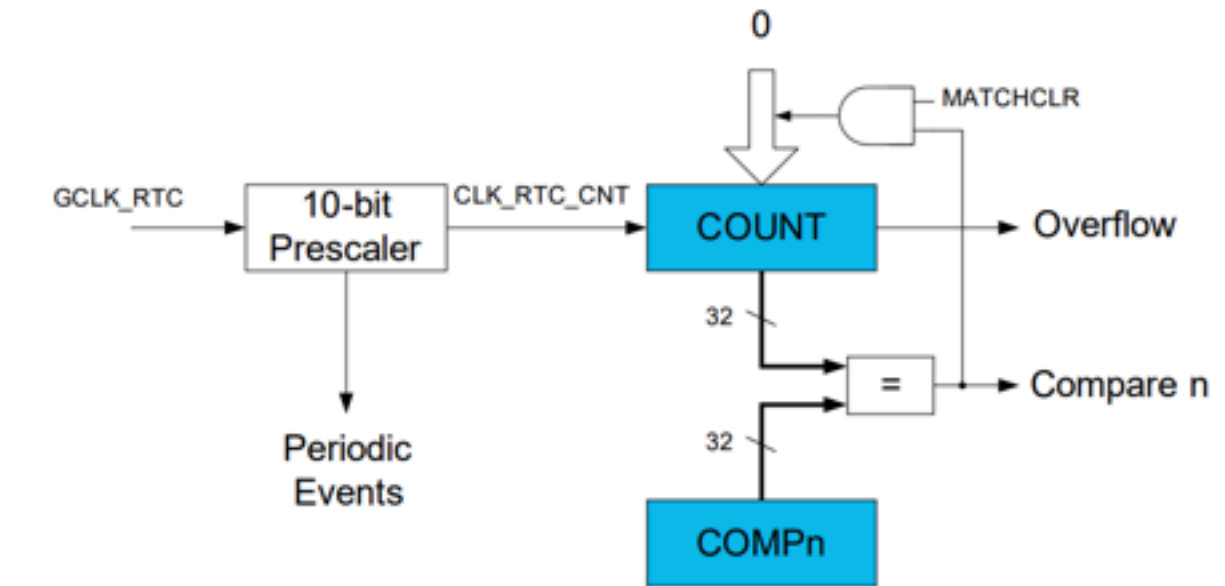

Figure 19-2. RTC Block Diagram (Mode 1 — 16-Bit Counter)

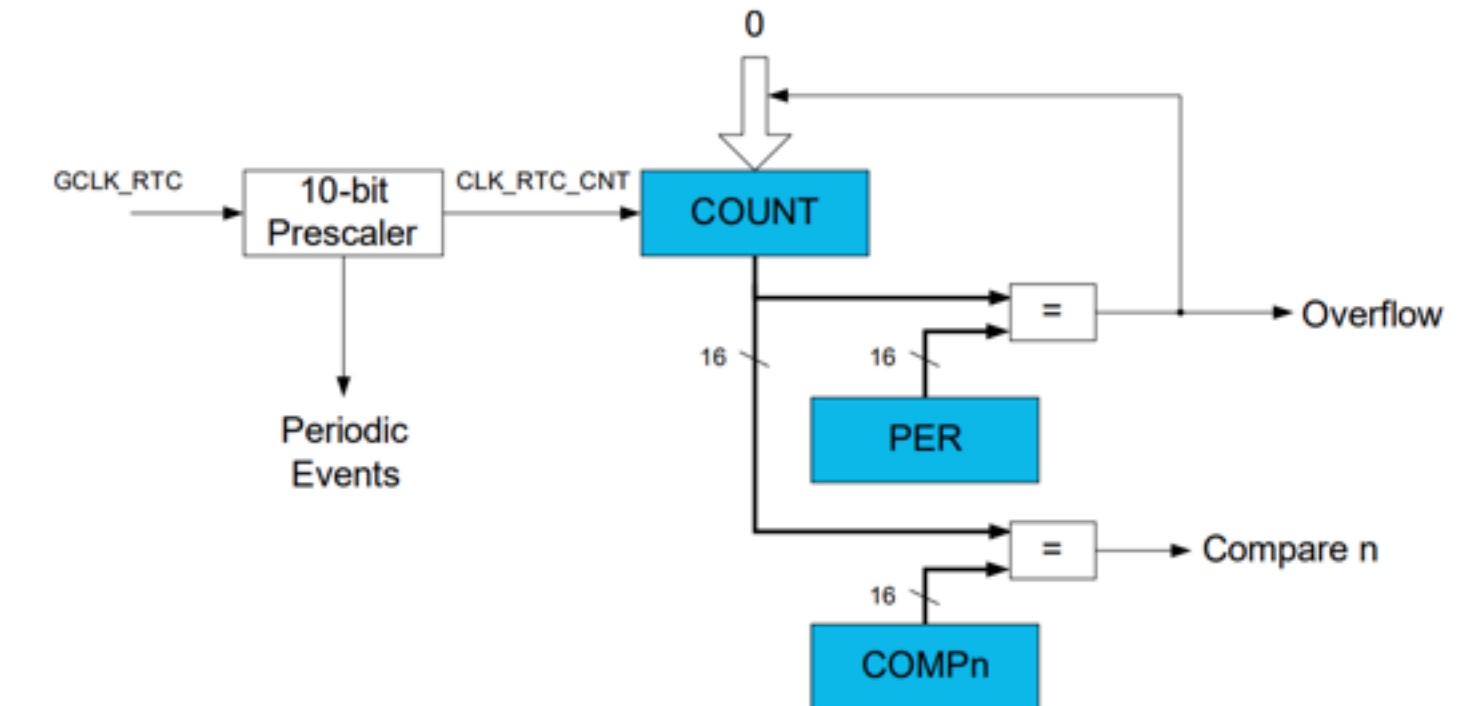
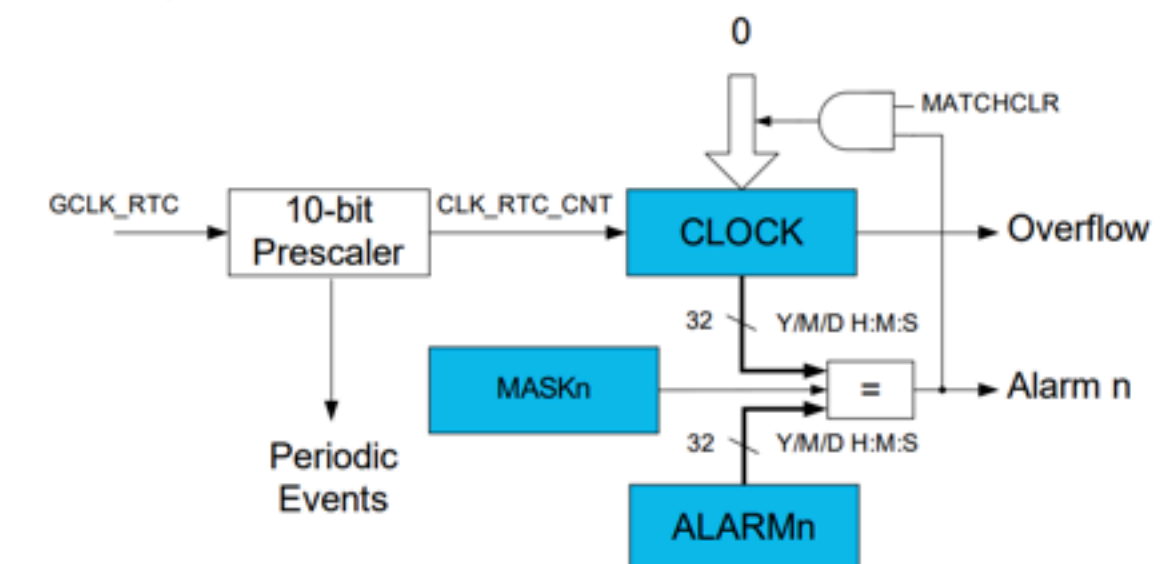
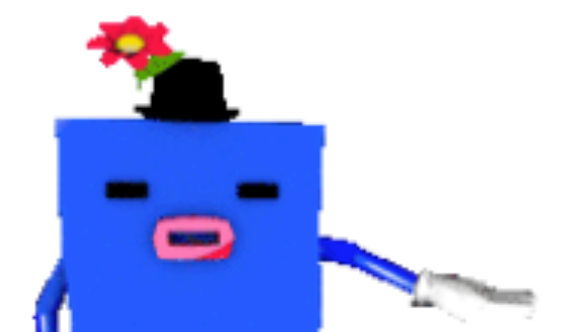
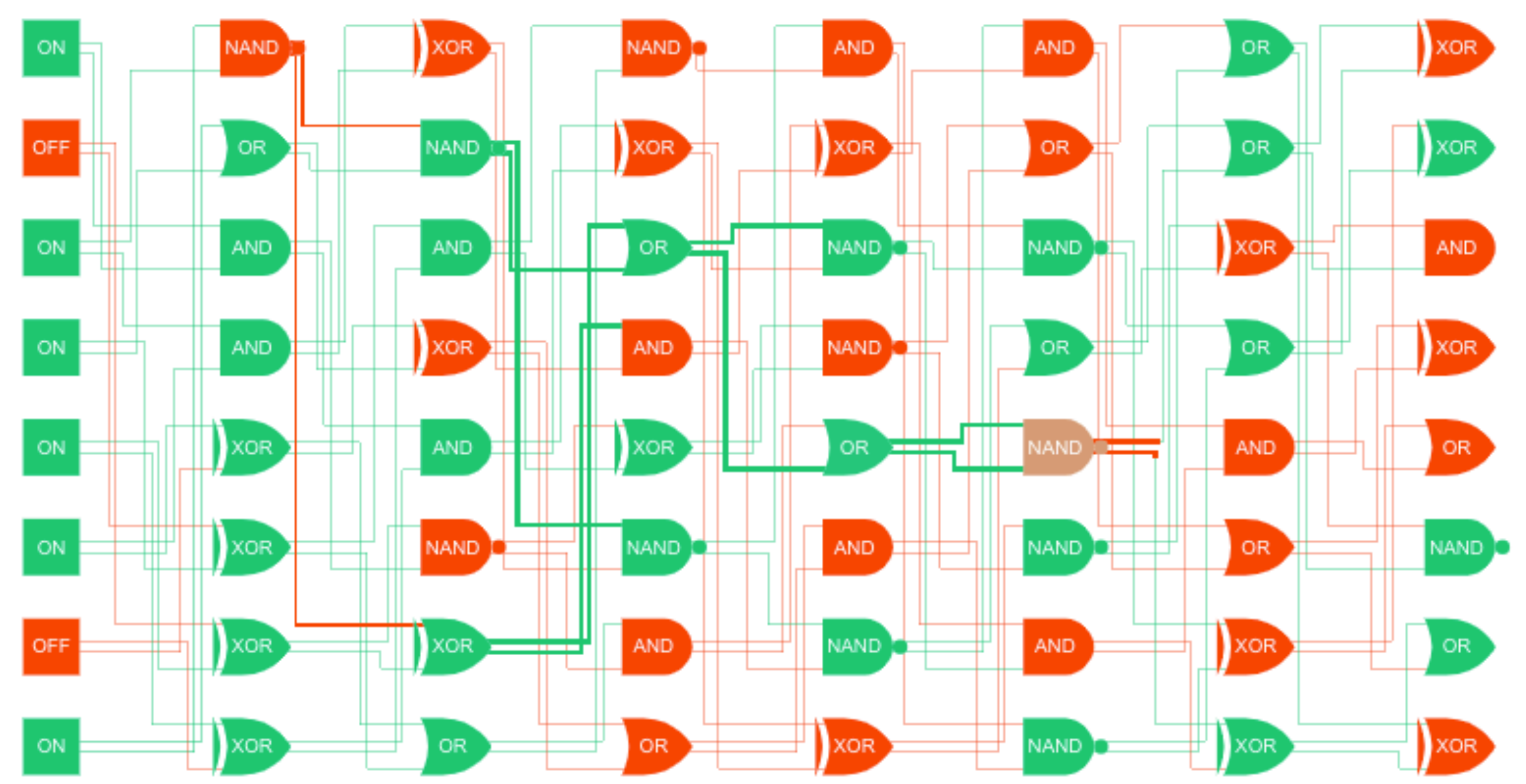

Figure 19-3. RTC Block Diagram (Mode 2 — Clock/Calendar)



Let's Begin

A computer is a clock with benefits. They all work the same, doing second-grade math, one step at a time: Tick, take a number and put it in box one. Tick, take another number, put it in box two. Tick, *operate* (an operation might be addition or subtraction) on those two numbers and put the resulting number in box one. Tick, check if the result is zero, and if it is, go to some other box and follow a new set of instructions.



This is simulated circuitry that's computing as you watch. The switches on the left turn the current on and off at random, and the logic gates direct the flow of the current. Click the boxes to change the circuits. Enough of these can compute anything computable.

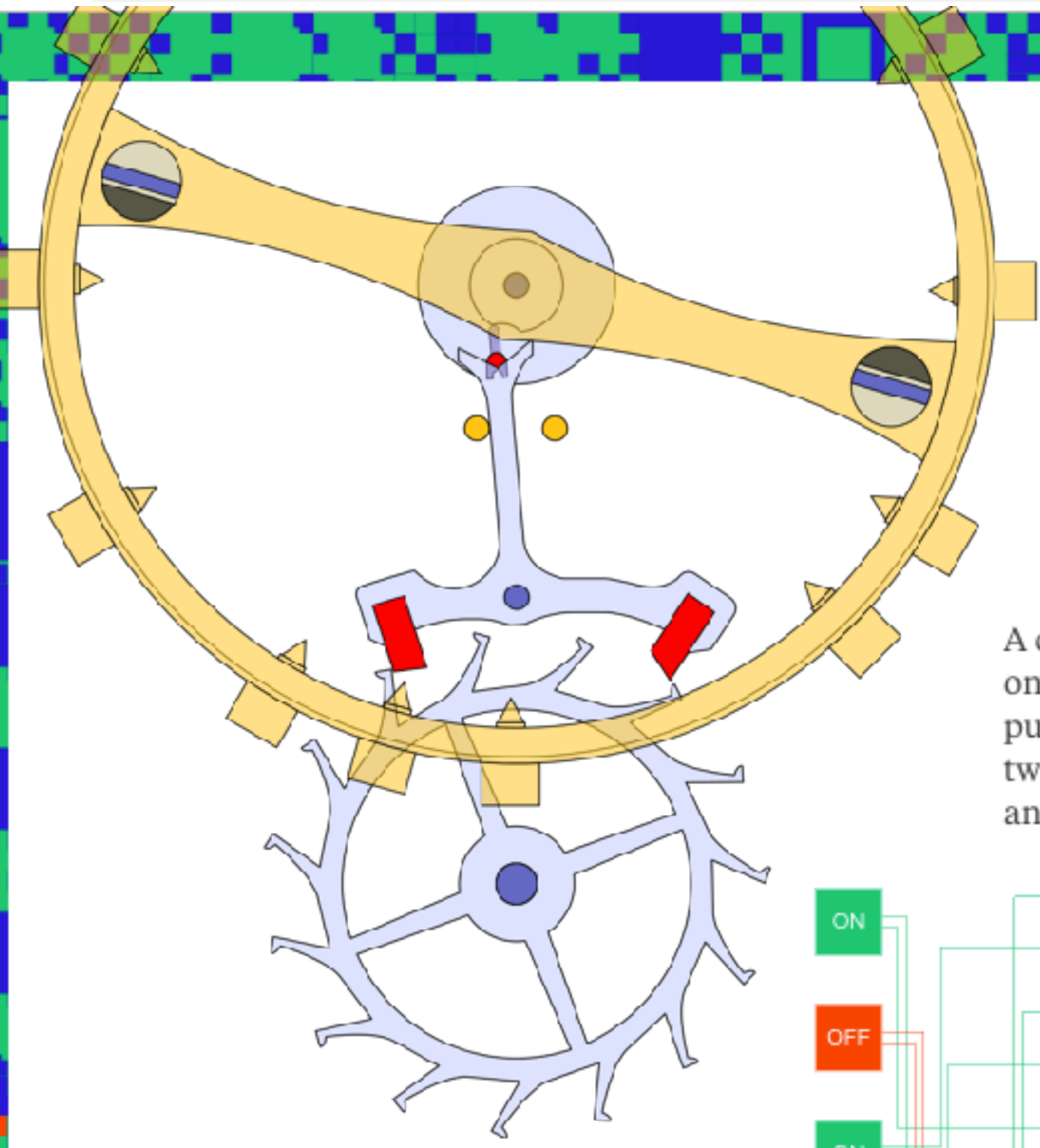

2

Let's Begin

A computer is a clock with benefits. They all work the same, doing second-grade math, one step at a time: Tick, take a number and put it in box one. Tick, take another number, put it in box two. Tick, *operate* (an operation might be addition or subtraction) on those two numbers and put the resulting number in box one. Tick, check if the result is zero, and if it is, go to some other box and follow a new set of instructions.

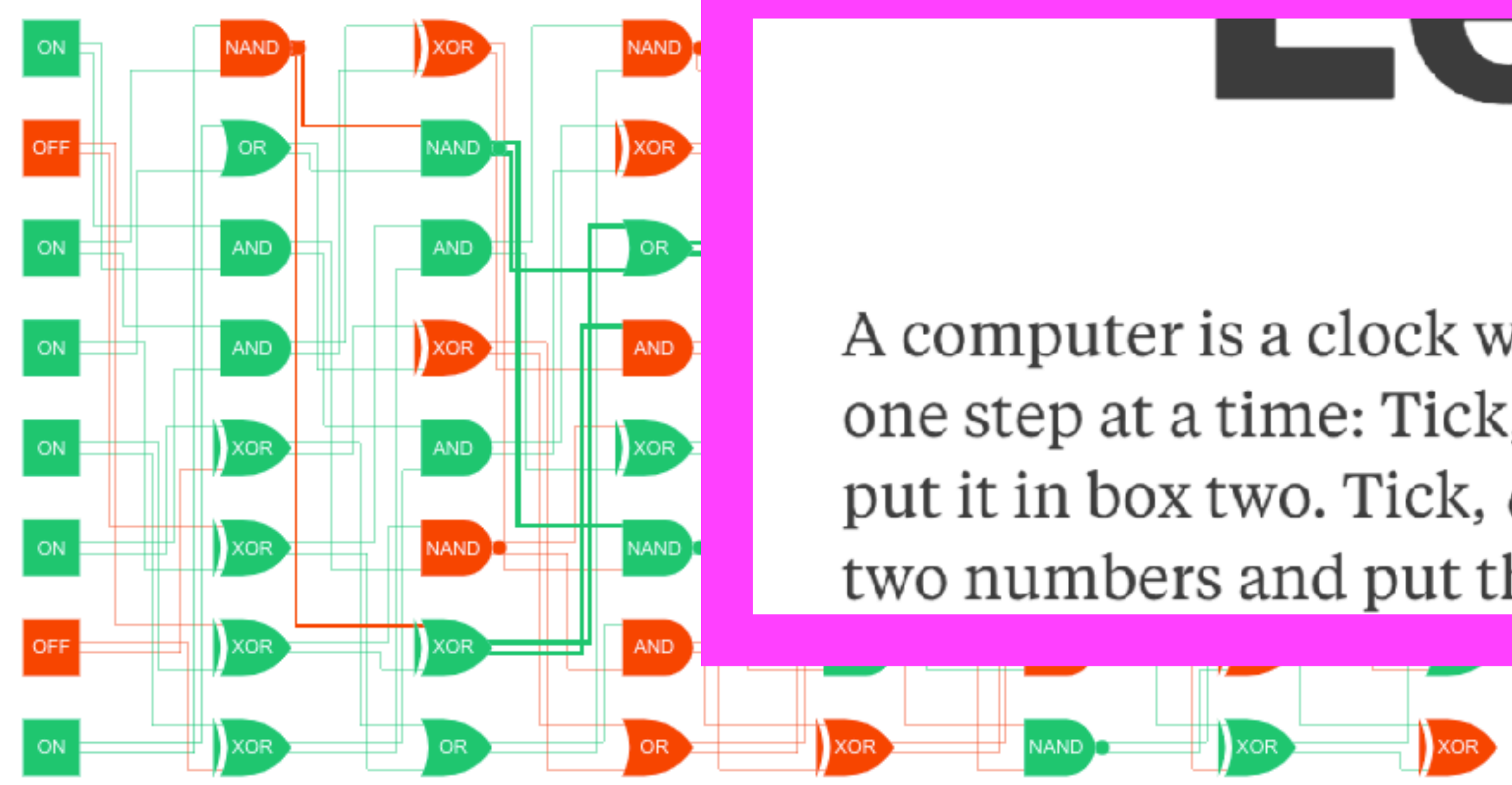

A computer is a clock with benefits. They all work the same, doing second-grade math, one step at a time: Tick, take a number and put it in box one. Tick, take another number, put it in box two. Tick, *operate* (an operation might be addition or subtraction) on those two numbers and put the resulting number in box one. Tick, check if the result is zero, and if it is, go to some other box and follow a new set of instructions.



This is simulated circuitry that's computing as you watch. The switches on the left turn the current on and off at random, and the logic gates direct the flow of the current. Click the boxes to change the circuits. Enough of these can compute anything computable.

```
sketch_sep29a | Arduino 1.8.13
sketch_sep29a
1 void setup() {
2   // put your setup code here, to run once:
3
4 }
5
6 void loop() {
7   // put your main code here, to run repeatedly:
8
9 }
```

ARDUINO

```
sketch_200929a | Processing 3.5.3
sketch_200929a
1 void setup() {
2
3 }
4
5 void draw() {
6
7 }
8
9
10
11
12
13
14
15
16
17
18
19
20
21
22
```

PROCESSING

```
p5.js Web Editor
editor.p5js.org
p5* File Edit Sketch Help English Hello, jfeddersen!
Auto-refresh Nettle cardboard
sketch.js Preview
1 function setup() {
2   createCanvas(400, 400);
3 }
4
5 function draw() {
6   background(220);
7 }
```

P5JS

TICK

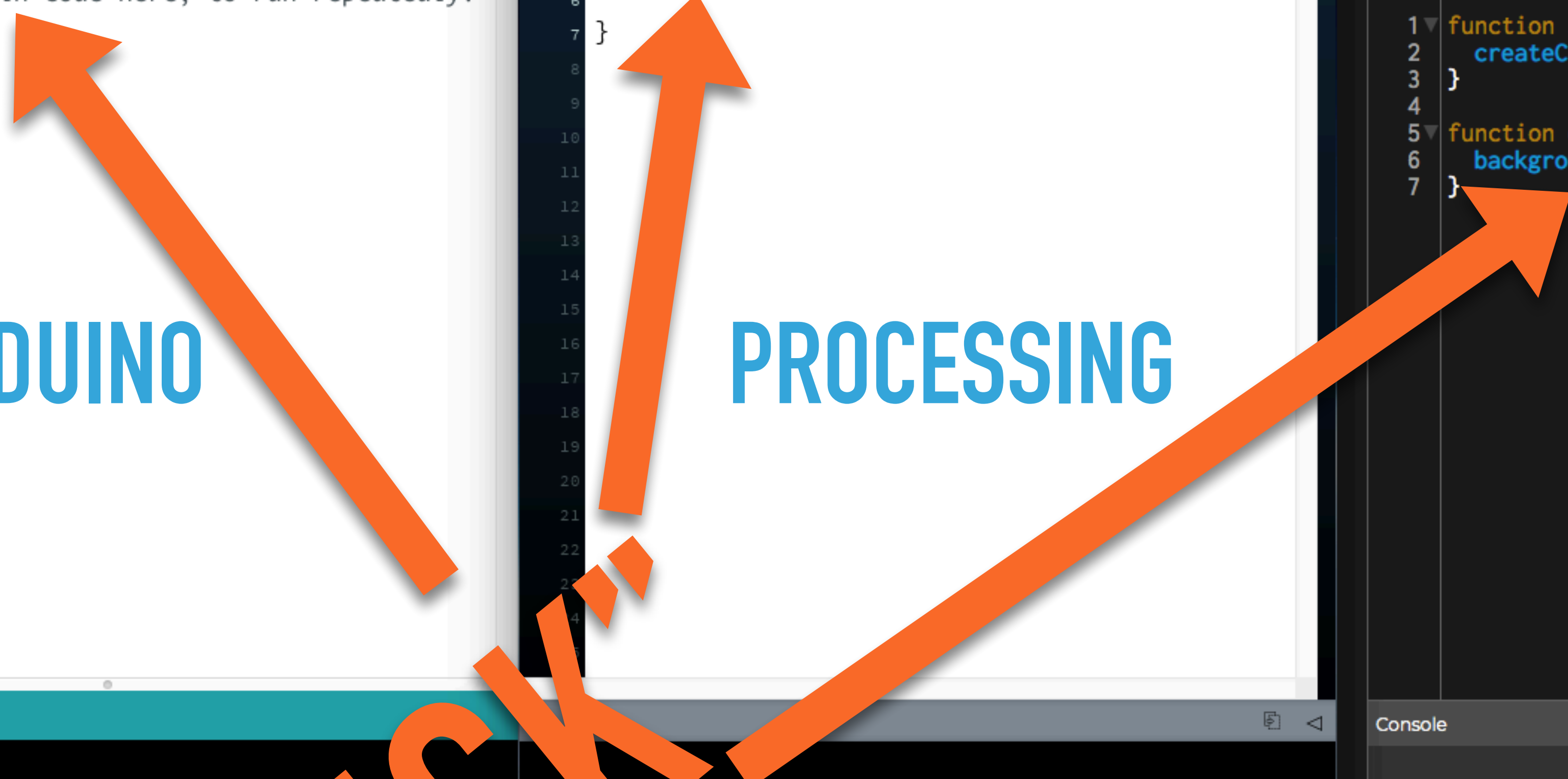

Arduino IDE status bar: Arduino ANO 33 IoT on /dev/usb/lm28960. Processing IDE status bar: Console Errors Updates 6. P5JS Web Editor status bar: Console Clear.

TIMER/COUNTERS ARE PRIMARY BUILDING BLOCKS OF MICROCONTROLLERS

Timing-based functions (analogWrite, tone, servo, etc.) make use of internal timers. These timers can trigger time-based interrupts, triggering functions.

However, accessing these timers typically involves architecture-specific registers and these change from chip to chip.

ATmega328 Block Diagram

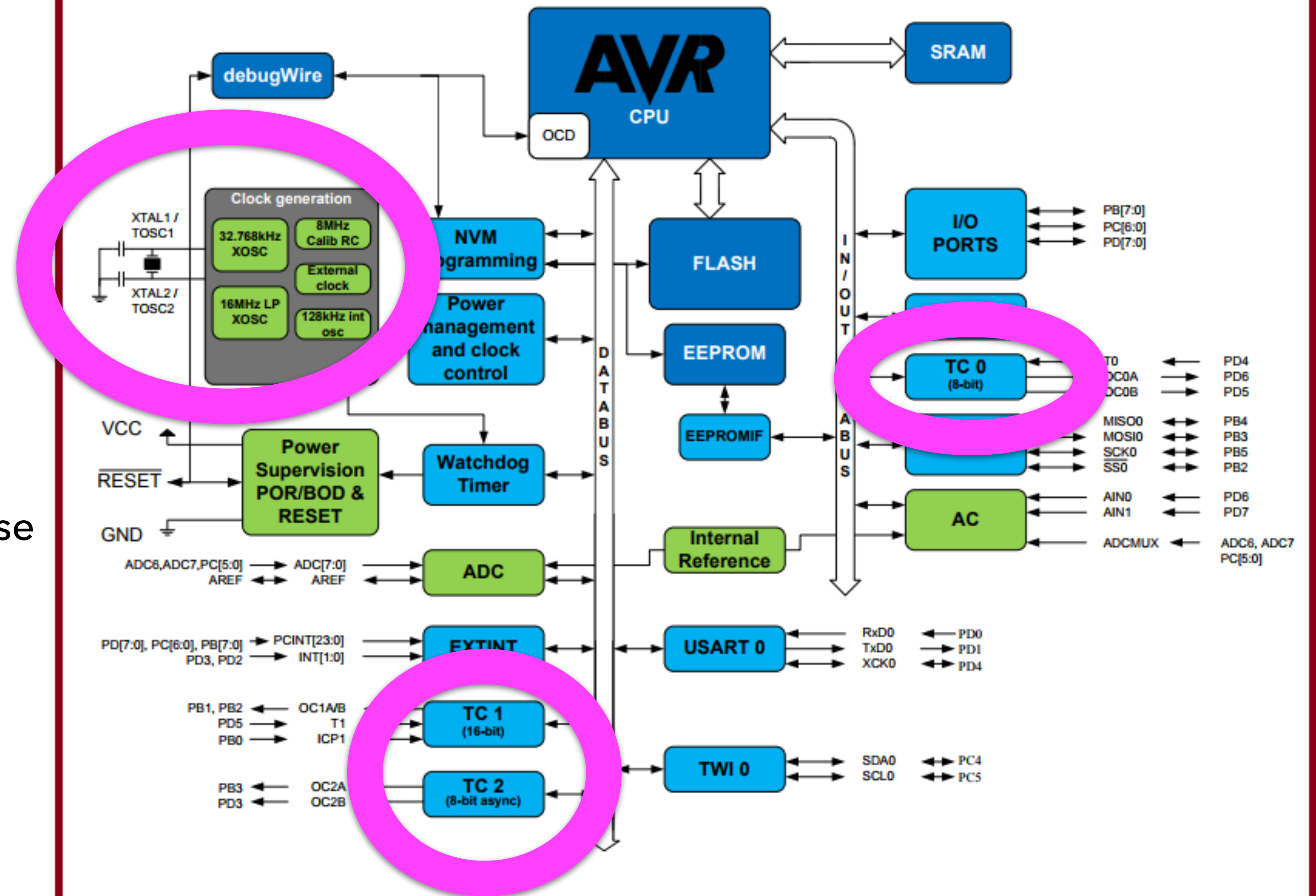

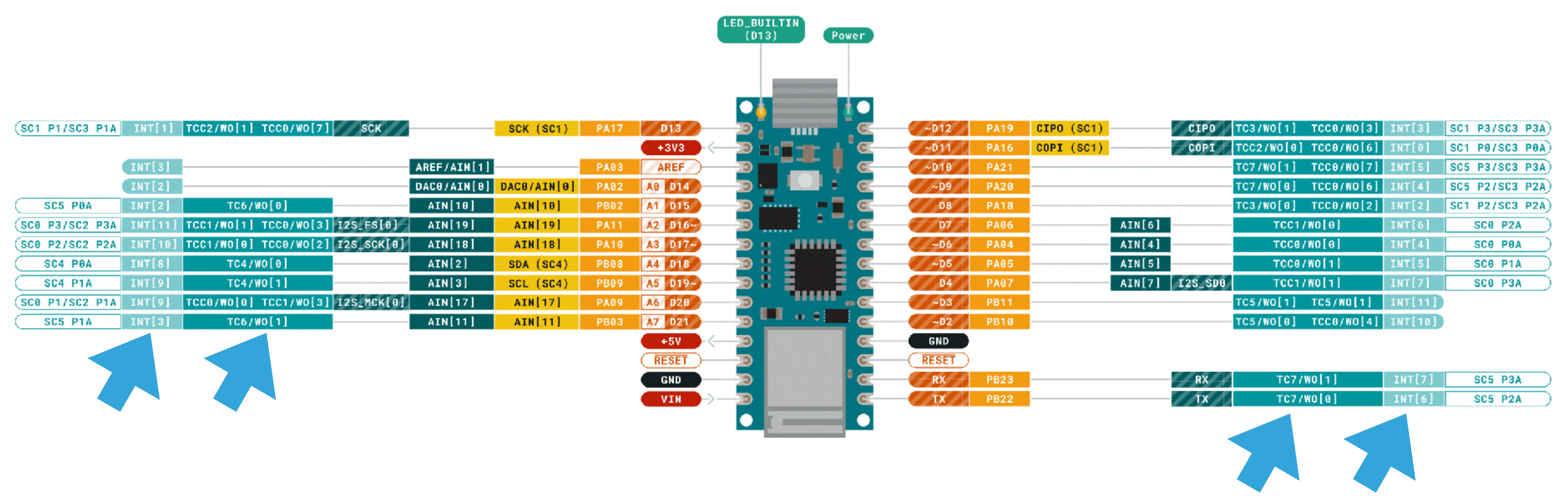

Ground	Digital Pin	Analog
Power	Analog Pin	Communication
LED	Other Pin	Timer
Internal Pin	Microcontroller's Power	Interrupt
SWD Pin	Default	Serial

- MAXIMUM** current per pin is 7mA
- MAXIMUM** source current is 46mA
- MAXIMUM** sink current is 65mA per pin group

VIN 5-21 V input to the board.

NOTE: CIP0/COPI have previously been referred to as MISO/MOSI



This work is licensed under the Creative Commons Attribution-ShareAlike 4.0 International License. To view a copy of this license, visit <http://creativecommons.org/licenses/by-sa/4.0/> or send a letter to Creative Commons, PO Box 1866, Mountain View, CA 94042, USA.

delay()

[Time]

Description

Pauses the program for the amount of time (in milliseconds) specified as parameter. (There are 1000 milliseconds in a second.)

Syntax

```
delay(ms)
```

Parameters

ms: the number of milliseconds to pause. Allowed data types: `unsigned long`.

Returns

Nothing

Example Code

The code pauses the program for one second before toggling the output pin.

```
int ledPin = 13;           // LED connected to digital pin 13

void setup() {
  pinMode(ledPin, OUTPUT); // sets the digital pin as output
}

void loop() {
  digitalWrite(ledPin, HIGH); // sets the LED on
  delay(1000);                // waits for a second
  digitalWrite(ledPin, LOW);  // sets the LED off
  delay(1000);                // waits for a second
}
```

Notes and Warnings

While it is easy to create a blinking LED with the `delay()` function and many sketches use short delays for such tasks as switch debouncing, the use of `delay()` in a sketch has significant drawbacks. No other reading of sensors, mathematical calculations, or pin manipulation can go on during the delay function, so in effect, it brings most other activity to a halt. For alternative approaches to controlling timing see the [Blink Without Delay](#) sketch, which loops, polling the `millis()` function until enough time has elapsed. More knowledgeable programmers usually avoid the use of `delay()` for timing of events longer than 10's of milliseconds unless the Arduino sketch is very simple.

Certain things do go on while the `delay()` function is controlling the Atmega chip, however, because the delay function does not disable interrupts. Serial communication that appears at the RX pin is recorded, PWM (`analogWrite`) values and pin states are maintained, and `interrupts` will work as they should.

```
void delay(unsigned long ms) {  
    uint32_t start = micros();  
  
    while (ms > 0) {  
        yield();  
        while ( ms > 0 && (micros() - start) >= 1000) {  
            ms--;  
            start += 1000;  
        }  
    }  
}
```

← micros() function on next slide

```
unsigned long micros() {
    unsigned long m;
    uint8_t oldSREG = SREG, t;

    cli();
    m = timer0_overflow_count;
#if defined(TCNT0)
    t = TCNT0;
#elif defined(TCNT0L)
    t = TCNT0L;
#else
    #error TIMER 0 not defined
#endif

#ifdef TIFR0
    if ((TIFR0 & _BV(TOV0)) && (t < 255))
        m++;
#else
    if ((TIFR & _BV(TOV0)) && (t < 255))
        m++;
#endif

    SREG = oldSREG;

    return ((m << 8) + t) * (64 / clockCyclesPerMicrosecond());
}
```

8-Bit Timer/Counter

Do some math to internal timer register to return run time in microseconds

<https://github.com/arduino/ArduinoCore-avr>

<https://web.engr.oregonstate.edu/~traylor/ece473/lectures/tcnt0.pdf>

Note - does not use micros()

```
/* Delay for the given number of microseconds. Assumes a 1, 8, 12, 16, 20 or 24 MHz clock. */
void delayMicroseconds(unsigned int us) {
    // call = 4 cycles + 2 to 4 cycles to init us(2 for constant delay, 4 for variable)
    // calling avrlib's delay_us() function with low values (e.g. 1 or
    // 2 microseconds) gives delays longer than desired.
    //delay_us(us);
    . . .

#ifdef F_CPU >= 16000000L
    // for the 16 MHz clock on most Arduino boards
    // for a one-microsecond delay, simply return. the overhead
    // of the function call takes 14 (16) cycles, which is 1us
    if (us <= 1) return; // = 3 cycles, (4 when true)

    // the following loop takes 1/4 of a microsecond (4 cycles)
    // per iteration, so execute it four times for each microsecond of
    // delay requested.
    us <<= 2; // x4 us, = 4 cycles

    // account for the time taken in the preceding commands.
    // we just burned 19 (21) cycles above, remove 5, (5*4=20)
    // us is at least 8 so we can subtract 5
    us -= 5; // = 2 cycles,
    . . .

    // busy wait
    __asm__ __volatile__ (
        "1: sbiw %0,1" "\n\t" // 2 cycles
        "brne 1b" : "=w" (us) : "0" (us) // 2 cycles
    );
    // return = 4 cycles
}

```

Several #elif directives covering different clock speeds

Countdown in Assembly:
SBIW - Subtract Immediate from Word
BRNE - Branch if Not Equal

ANALOGWRITE

```
else
{
    switch(digitalPinToTimer(pin))
    {
        // XXX fix needed for atmega8
        #if defined(TCCR0) && defined(COM00) && !defined(__AVR_ATmega8__)
        case TIMER0A:
            // connect pwm to pin on timer 0
            sbi(TCCR0, COM00);
            OCR0 = val; // set pwm duty
            break;
        #endif

        #if defined(TCCR0A) && defined(COM0A1)
        case TIMER0A:
            // connect pwm to pin on timer 0, channel A
            sbi(TCCR0A, COM0A1);
            OCR0A = val; // set pwm duty
            break;
        #endif

        #if defined(TCCR0A) && defined(COM0B1)
        case TIMER0B:
            // connect pwm to pin on timer 0, channel B
            sbi(TCCR0A, COM0B1);
            OCR0B = val; // set pwm duty
            break;
        #endif

        #if defined(TCCR1A) && defined(COM1A1)
        case TIMER1A:
            // connect pwm to pin on timer 1, channel A
            sbi(TCCR1A, COM1A1);
            OCR1A = val; // set pwm duty
```

TONE

```
// Set timer specific stuff
// All timers in CTC mode
// 8 bit timers will require changing prescalar values,
// whereas 16 bit timers are set to either ck/1 or ck/64 prescalar
switch (_timer)
{
    #if defined(TCCR0A) && defined(TCCR0B) && defined(WGM01)
    case 0:
        // 8 bit timer
        TCCR0A = 0;
        TCCR0B = 0;
        bitWrite(TCCR0A, WGM01, 1);
        bitWrite(TCCR0B, CS00, 1);
        timer0_pin_port = portOutputRegister(digitalPinToPort(_pin));
        timer0_pin_mask = digitalPinToBitMask(_pin);
        break;
    #endif

    #if defined(TCCR1A) && defined(TCCR1B) && defined(WGM12)
    case 1:
        // 16 bit timer
        TCCR1A = 0;
        TCCR1B = 0;
        bitWrite(TCCR1B, WGM12, 1);
        bitWrite(TCCR1B, CS10, 1);
        timer1_pin_port = portOutputRegister(digitalPinToPort(_pin));
        timer1_pin_mask = digitalPinToBitMask(_pin);
        break;
    #endif
```

Example program -- AVR Libc

microchip.com/webdoc/AVRLibcReferenceManual/assembler_1ass

MICROCHIP AVR Libc Reference Manual avr-libc and assembler programs

CONTENTS SEARCH

TIMER Go

Results for: timer

- Watchdog timer handling
- Why do some 16-bit timer registers sometimes get trashed?
- Interrupts
- The Source Code
- Combining C and assembly source files
- Allowing specific system-wide interrupts
- asmdemo.c
- Examining the Object File
- isrs.S
- The Project
- Example program
- How do I perform a software reset of the AVR?
- Part 5: main()
- Macro wdt_reset
- Basic busy-wait delay loops
- What is all this _BV() stuff about?

Example program

The following annotated example features a simple 100 kHz square wave generator using an AT90S1200 clocked with a 10.7 MHz crystal. Pin PD6 will be used for the square wave output.

```
#include <avr/io.h>           : Note [1]
work = 16                    : Note [2]
tmp = 17
inttmp = 19
intsav = 0
SQUARE = PD6                ; Note [3]

tmconst= 10700000 / 200000
fuzz= 8

.section .text
.global main
main:
rcall ioinit
1:
rjmp 1b

.global TIMERO_OVF_vect
TIMERO_OVF_vect:
ldi inttmp, 256
out _SFR_IO_ADDR(TIMSK), inttmp

in intsav, _SFR_IO_ADDR(TIMSK)

sbic _SFR_IO_ADDR(TIMSK), 1f
rjmp 1f
sbi _SFR_IO_ADDR(TIMSK), 2f
rjmp 2f
1:
cbi _SFR_IO_ADDR(TIMSK), 2f
2:

out _SFR_IO_ADDR(TIMSK), intsav
reti

ioinit:
sbi _SFR_IO_ADDR(DDRD), SQUARE

ldi work, _BV(TOIE0)
out _SFR_IO_ADDR(TIMSK), work

ldi work, _BV(CS00)          : tmr0: CK/1
out _SFR_IO_ADDR(TCCR0), work

ldi work, 256 - tmconst
```

Example program -- AVR Libc

microchip.com/webdoc/AVRLibcReferenceManual/assembler_1ass

MICROCHIP AVR Libc Reference Manual avr-libc and assembler programs

CONTENTS SEARCH

TIMER Go

Results for: timer

- Watchdog timer handling
- Why do some 16-bit timer registers sometimes get trashed?
- Interrupts
- The Source Code

Note [4]

The assembler uses integer operations in the host-defined integer size (32 bits or longer) when evaluating expressions. This is in contrast to the C compiler that uses the C type `int` by default in order to calculate constant integer expressions. In order to get a 100 kHz output, we need to toggle the PD6 line 200000 times per second. Since we use `timer 0` without any prescaling options in order to get the desired frequency and accuracy, we already run into serious timing considerations: while accepting and processing the `timer` overflow interrupt, the `timer` already continues to count. When pre-loading the `TCCR0` register, we therefore have to account for the number of clock cycles required for interrupt acknowledge and for the instructions to reload `TCCR0` (4 clock cycles for interrupt acknowledge, 2 cycles for the jump from the interrupt vector, 2 cycles for the 2 instructions that reload `TCCR0`). This is what the constant `fuzz` is for.

Note [5]

External functions need to be declared to be `.global`. `main` is the application entry point that will be jumped to from the initialization routine in `crts1200.o`.

- Macro wdt_reset
- Basic busy-wait delay loops
- What is all this _BV() stuff about?

here only since actually, all the following instructions would not modify SREG either, but that's not commonly the case.) Also, it must be ensured that registers used inside the interrupt routine do not conflict with those used outside. In the case of a RAM-less device like the AT90S1200, this can only be achieved by agreeing on a set of registers to be used exclusively inside the interrupt routine. There would not be any other chance to "save" a register anywhere. If the interrupt routine is to be linked together with C modules, care must be taken to follow the [register usage guidelines](#) imposed by the C compiler. Also, any register modified inside the interrupt service needs to be saved, usually on the stack.

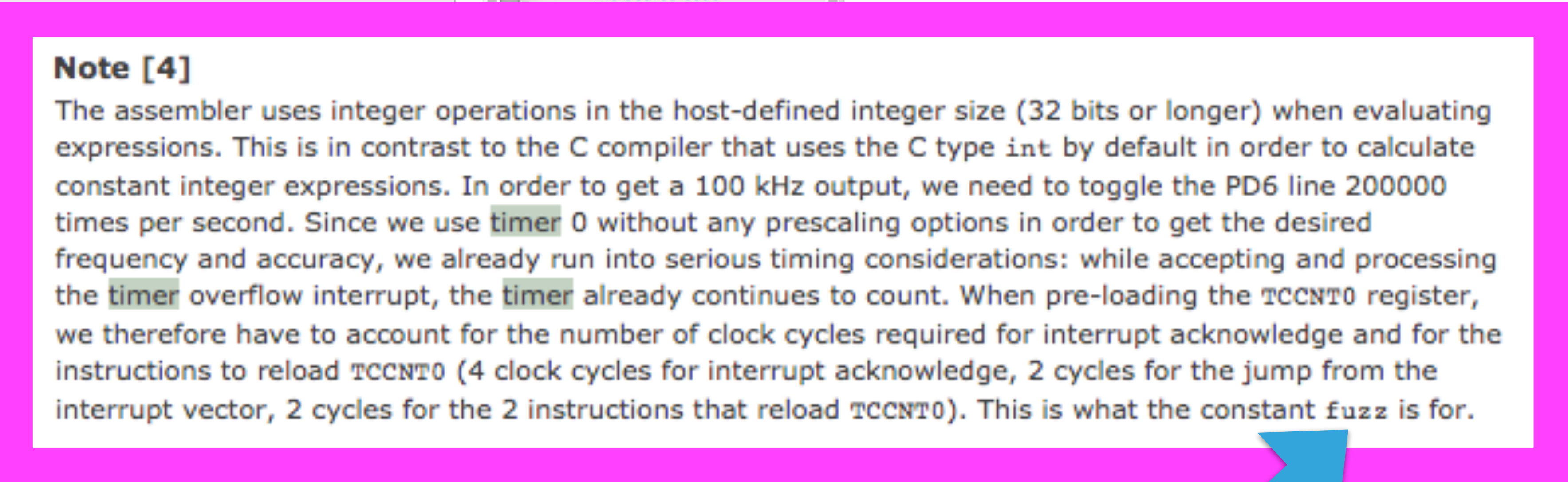

delay()

[Time]

Description

Pauses the program for the amount of time (in milliseconds) specified as parameter. (There are 1000 milliseconds in a second.)

Syntax

`delay(ms)`

Param

ms: the

Return

Nothing

Exam

The co

```
int led
```

```
void s
```

```
pinM
```

```
}
```

```
void loop() {
```

```
  digitalWrite(ledPin, HIGH); // sets the LED on
```

```
  delay(1000); // waits for a second
```

```
  digitalWrite(ledPin, LOW); // sets the LED off
```

```
  delay(1000); // waits for a second
```

```
}
```

Notes and Warnings

While it is easy to create a blinking LED with the `delay()` function and many sketches use short delays for such tasks as switch debouncing, the use of `delay()` in a sketch has significant drawbacks. No other reading of sensors, mathematical calculations, or pin manipulation can go on during the delay function, so in effect, it brings most other activity to a halt. For alternative approaches to controlling timing see the [Blink Without Delay](#) sketch, which loops, polling the `millis()` function until enough time has elapsed. More knowledgeable programmers usually avoid the use of `delay()` for timing of events longer than 10's of milliseconds unless the Arduino sketch is very simple.

Certain things do go on while the `delay()` function is controlling the Atmega chip, however, because the delay function does not disable interrupts. Serial communication that appears at the RX pin is recorded, PWM (`analogWrite`) values and pin states are maintained, and `interrupts` will work as they should.

see the [Blink Without Delay](#) sketch, which loops, polling the `millis()` function until enough time has elapsed. More knowledgeable programmers usually avoid the use of `delay()` for timing of events longer than 10's of milliseconds unless the Arduino sketch is very simple.

Certain things do go on while the `delay()` function is controlling the Atmega chip, however, because the delay function does not disable interrupts. Serial communication that appears at the RX pin is recorded, PWM (`analogWrite`) values and pin states are maintained, and `interrupts` will work as they should.

INTERRUPTS

Microcontrollers can process **interrupts**: functions called automatically by hardware changes.

Changes include:

- ▶ **external**, such as voltage changes on an interrupt-enabled pin, or
- ▶ **internal**, from changes in an internal hardware **timer** (basically, a counter incrementing each clock cycle) reaching a certain value.

POLLING

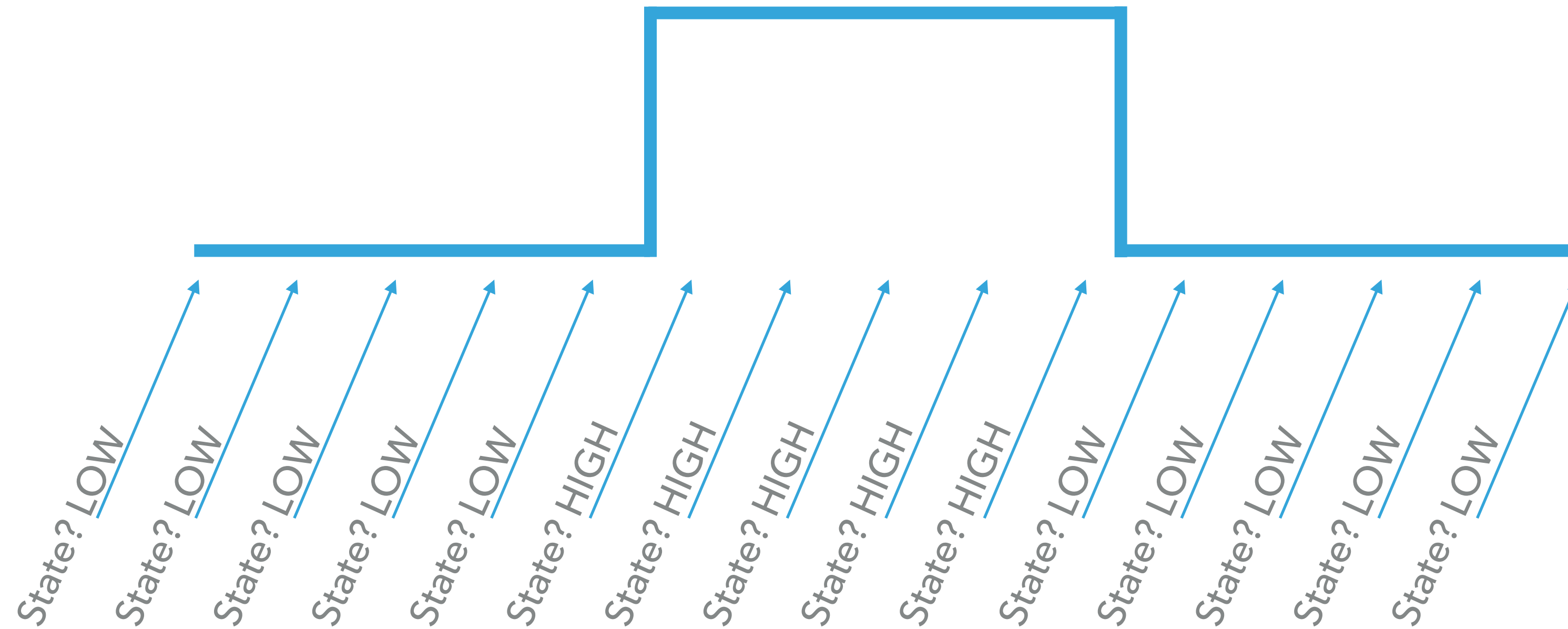

In main loop, use digital read to check the state of an input pin. Decide what to do if it is low, high, changed, etc.

INTERRUPTS

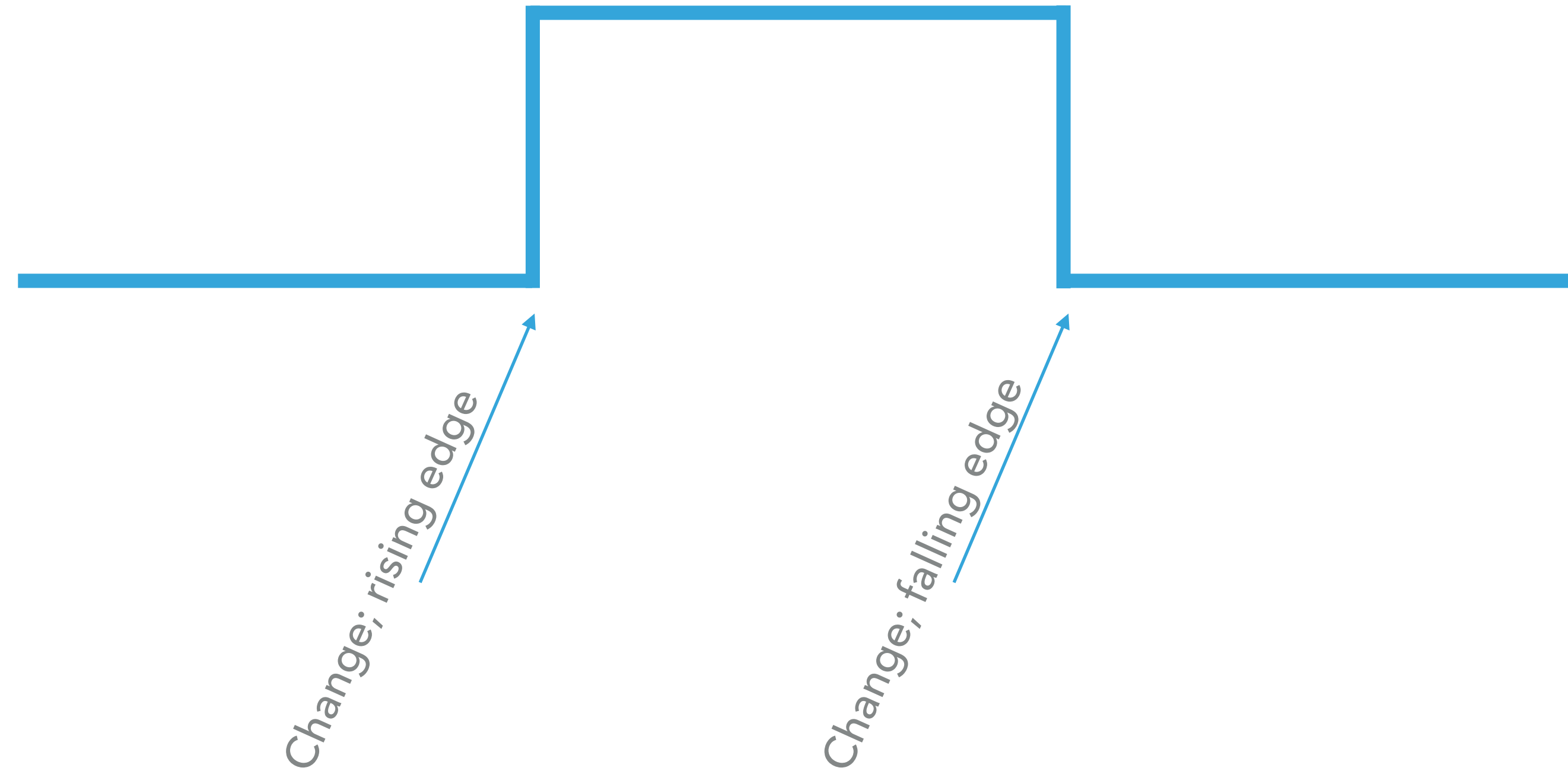

Define interrupt service routines (ISRs) for hardware changes: rising edge, falling edge, and/or change. These will be called immediately when the pin changes.

INTERRUPTS

Basic Idea: You identify a function to call when an interrupt even occurs. This function is the "Interrupt Service Routine" or ISR. ISRs should run as quickly as possible. Any variables accessed by the ISR must be declared "Volatile"

1 `volatile bool ledState = LOW; //note new qualifier "volatile" - this indicates a variable may change while handling an interrupt`

2 `attachInterrupt(digitalPinToInterrupt(INTERRUPT_PIN), myISR, CHANGE);
// trigger when button pressed, but not when released.`

3 `void myISR() {isrCount ++;
 if ((long)(micros() - lastMicros) > debounceTimeMicros) {
 ledState = !ledState;
 lastMicros = micros();
 }
}`

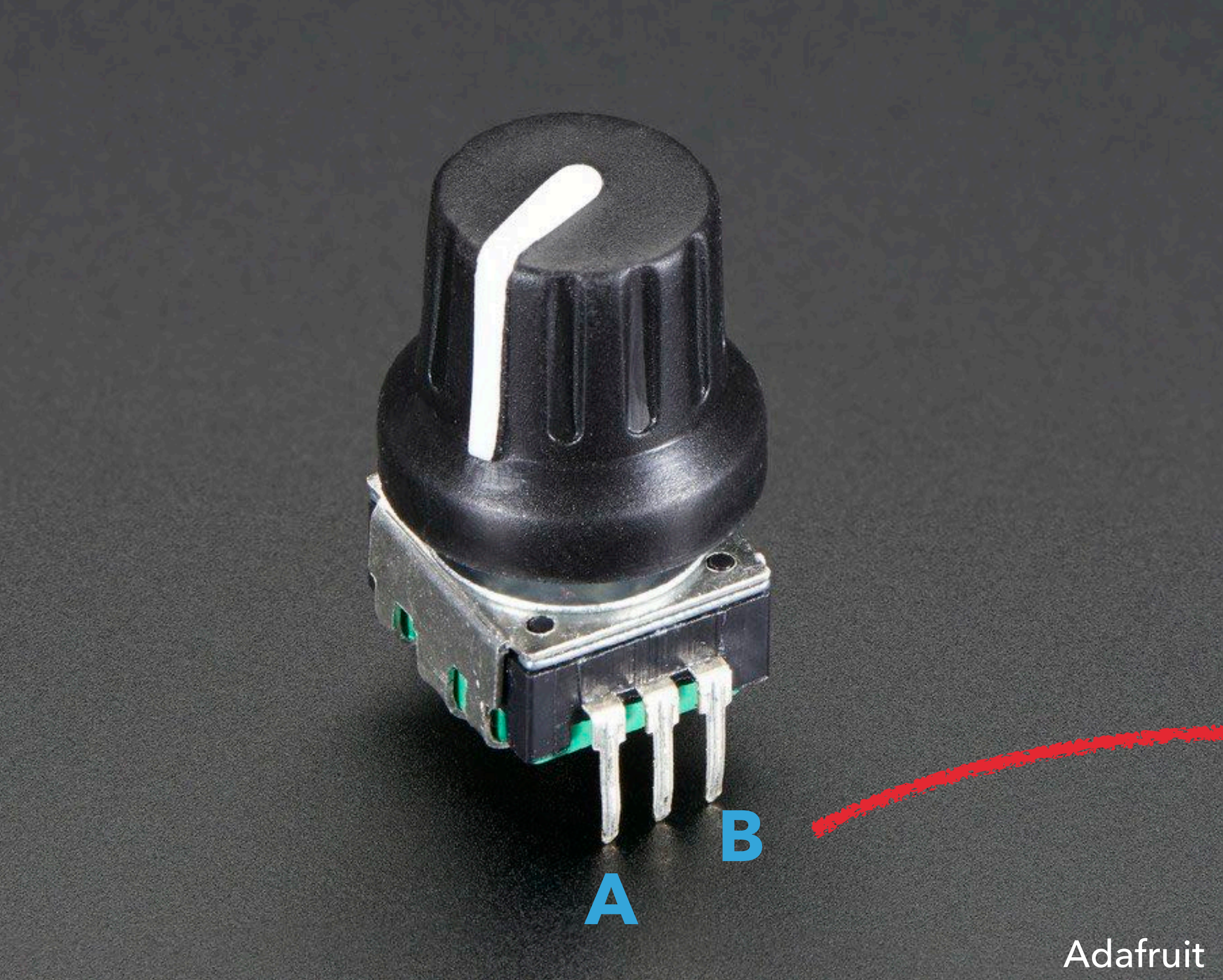

INTERRUPTS

Excellent for resolving fast-changing inputs such as the signals from rotary encoders.

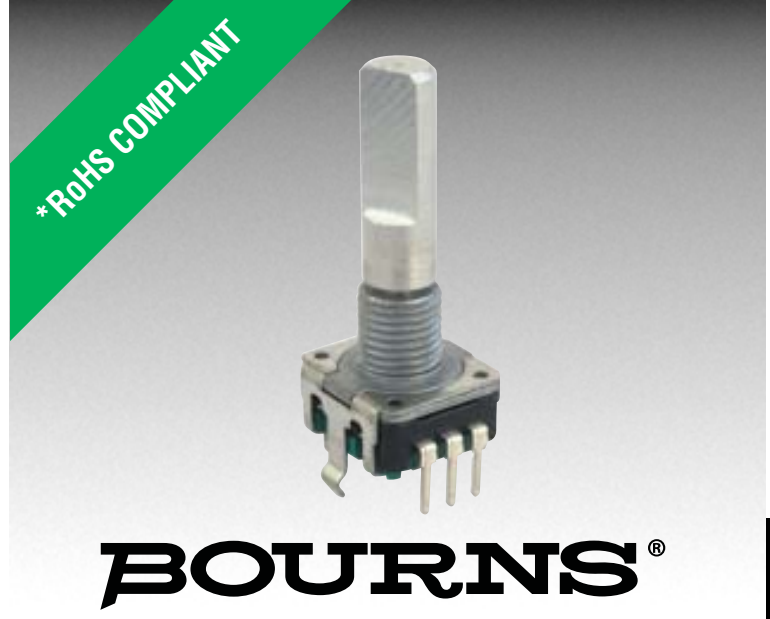

- Features**
- Push switch option
 - Compact, rugged design
 - High reliability
 - Metal bushing/shaft



PEC11 Series - 12 mm Incremental Encoder

Electrical Characteristics

Output	2-bit quadrature code
Closed Circuit Resistance	3 ohms maximum
Contact Rating	1 mA @ 5 VDC
Insulation Resistance	100 megohms @ 250 VDC
Dielectric Withstanding Voltage	
Sea Level	300 VAC minimum
Electrical Travel.....	Continuous
Contact Bounce (15 RPM).....	5.0 ms maximum**
RPM (Operating).....	60 maximum**

Environmental Characteristics

Operating Temperature Range	-30 °C to +70 °C (-22 °F to +158 °F)
Storage Temperature Range	-40 °C to +85 °C (-40 °F to +185 °F)
Humidity	MIL-STD-202, Method 103B, Condition B
Vibration	30 G
Contact Bounce.....	10~55~10 Hz / 1 min. / Amplitude 1.5 mm
Shock	100 G
Rotational Life	30,000 cycles minimum
Switch Life.....	20,000 cycles minimum
IP Rating	IP 40

Mechanical Characteristics

Mechanical Angle	360 ° continuous
Torque	
Running	50 to 200 gf.cm (0.68 to 2.7 oz.-in.)
Mounting.....	10.2 kgf.cm (8.83 lb.-in.) maximum
Shaft Side Load (Static).....	2.04 kgf (4.5 lbs.) minimum
Weight	5 gm (0.17 oz.) maximum
Terminals	Printed circuit board terminals
Soldering Condition	
Wave Soldering.....	Sn95.5/Ag2.3/Cu0.7 solder with no-clean flux: 260 °C max. for 3-5 seconds
Hand Soldering.....	Not recommended
Hardware	One flat washer and one mounting nut supplied with each encoder

Switch Characteristics

Switch Type	Contact Push ON Momentary SPST
Power Rating (Resistive Load)	10 mA at 5 V DC
Switch Travel	0.5 ± 0.2 mm
Switch Actuation Force	61 ± 3 gf (1.37 ± 0.07 oz.-in.)

How To Order

Model _____ **PEC11 - 4 0 20 F - S 0012**

Terminal Configuration _____	4 = PC Pin Horizontal/Rear Facing
Detent Option _____	0 = No Detents (12, 18, 24 pulses) 1 = 18 Detents (18 pulses) 2 = 24 Detents (12, 24 pulses) 3 = 12 Detents (12 pulses)
Standard Shaft Length _____	15 = 15.0 mm 20 = 20.0 mm 25 = 25.0 mm

Quadrature Output Table

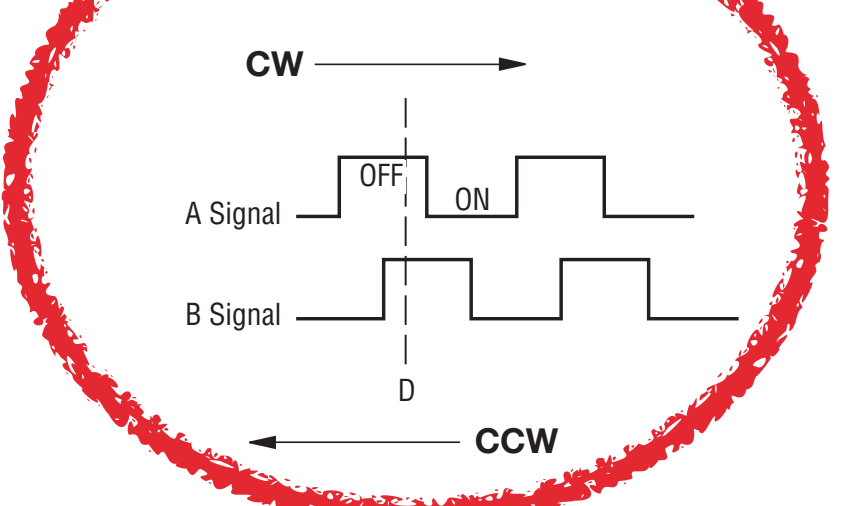

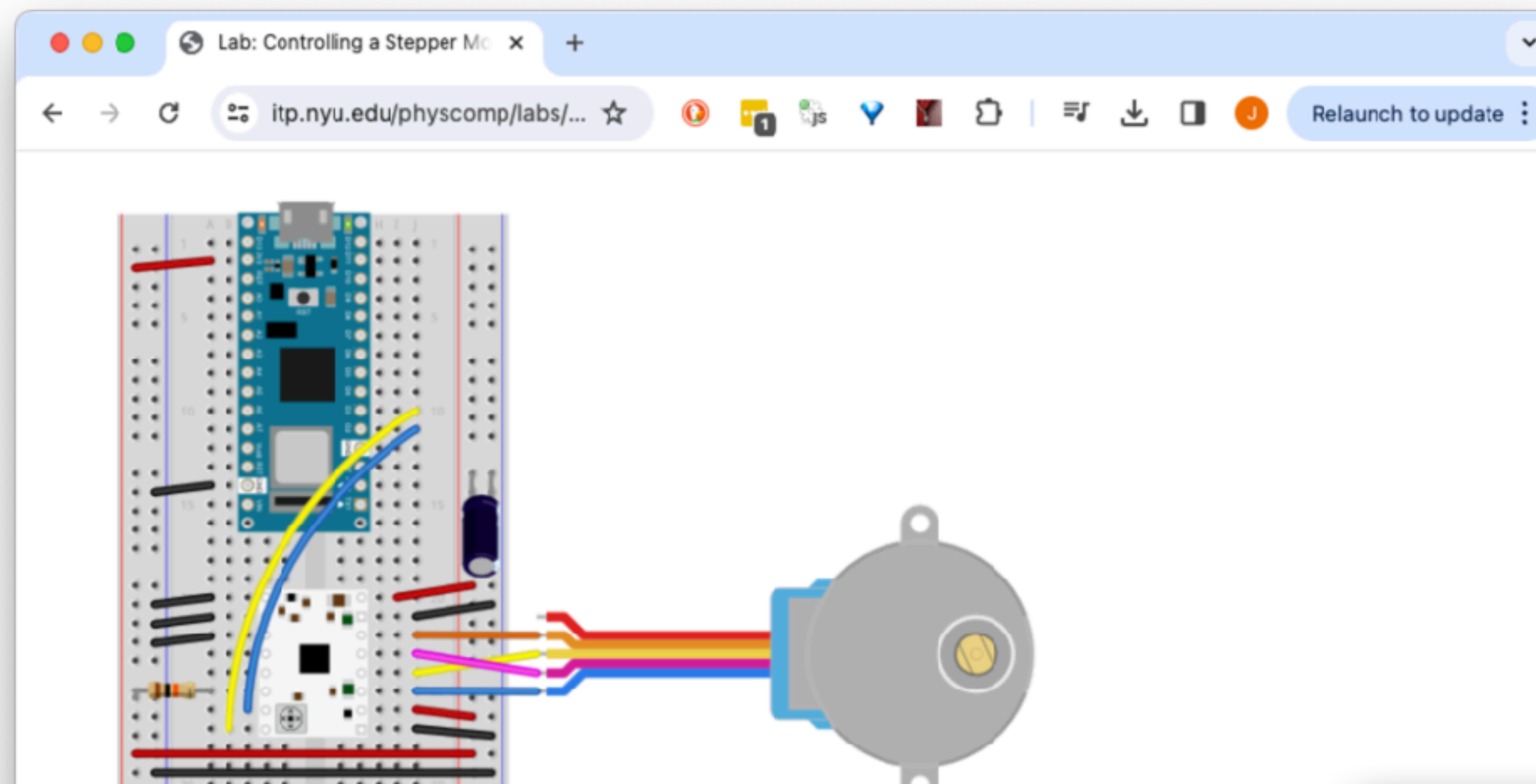

Figure 16. Breadboard diagram of an STSPIN220 stepper motor driver and stepper motor connected to an Arduino Nano 33 IoT.

Made with [Fritzing](#)

Once you have the motor and the driver connected, you're ready to program the microcontroller.

Program the microcontroller

You don't need a library for a step and direction controller, though there are several out there, to do things like ramp the speed up and down, ease in and out, and so forth. All you need to do to move the motor is to set the direction pin, and to pulse the motor high then return to low. A 3-millisecond pulse will do the job reliably. If you need more speed, you can try reducing this down to 2 or even 1ms, once you know the motor's

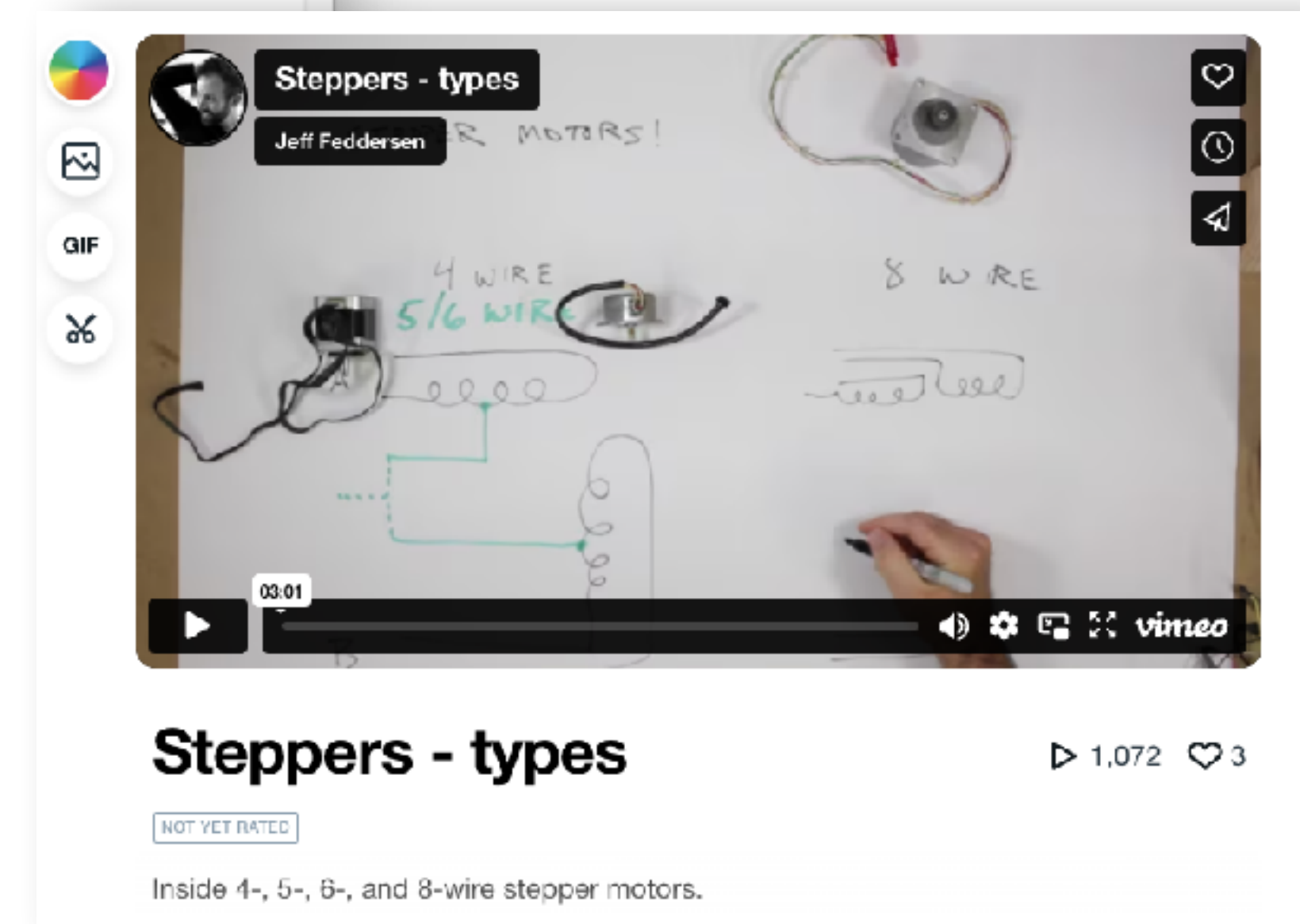

STEPPERS

Almost the "inverse" of encoders: send pulsed info to the stepper and it turns. See [pomp site](#) for tons of info.

<https://itp.nyu.edu/physcomp/labs/motors-and-transistors/lab-controlling-a-stepper-motor-with-a-step-and-direction-driver/>